

IMPORTANT SAFETY INSTRUCTIONS

1. Read Instructions

All the safety and operating instructions should be read before the product is operated.

2. Retain Instructions

The safety and operating instructions should be retained for future reference.

3. Heed Warnings

All warnings on the product and the operating instructions should be adhered to.

4. Follow Instructions

All operating and use instructions should be followed.

5. Cleaning

Unplug this product from the wall outlet before cleaning. Do not use liquid cleaners or aerosol cleaners. Use a damp cloth for cleaning.

6. Attachments

Do not use attachments not recommended by the product manufacturer as they may cause hazards.

7. Water and Moisture

Do not use this product near water - for example, near a bath tub, wash bowl, kitchen sink, or laundry tub; in a wet basement; or near a swimming pool; and the like.

8. Accessories

Do not place this product on an unstable cart, stand, tripod, bracket, or table. The product may fall, causing serious injury to a child or adult, and serious damage to the product. Use only with a cart, stand, tripod, bracket, or table recommended by the manufacturer, or sold with the product. Any mounting of the product should follow the manufacturer's instructions, and should use a mounting accessory recommended by the manufacturer.

9. Moving

A product and cart combination should be moved with care.

Quick stops, excessive force, and uneven surfaces may cause the product and cart combination to overturn.

10. Ventilation

Slots and openings in the cabinet are provided for ventilation and to ensure reliable operation of the product and to protect it from overheating, and these openings must not be blocked or covered.

The openings should never be blocked by placing the product on a bed, sofa, rug, or other similar surface. This product should not be placed in a built-in installation such as a bookcase or rack unless proper ventilation is provided or the manufacturer's instructions have been adhered to.

11. Power Sources

This product should be operated only from the type of power source indicated on the marking label. If you are not sure of the type of power supply to your home, consult your product dealer or local power company. For products intended to operate from battery power, or other sources, refer to the operating instructions.

12. Grounding or Polarization

This product is equipped with a three-wire grounding-type plug a plug having a third (grounding) pin. This plug will only fit into a grounding-type power outlet. This is a safety feature. If you are unable to insert the plug into the outlet, contact your electrician to replace your obsolete outlet. Do not defeat the safety purpose of the grounding-type plug.

13. Power-Cord Protection

Power-supply cords should be routed so that they are not likely to be walked on or pinched by items placed upon or against them, paying particular attention to cords at plug, convenience receptacles, and the point where they exit from the product.

14. Lightning

For added protection for this product during a lightning storm, or when it is left unattended and unused for long periods of time, unplug it from the wall outlet. This will prevent damage to the product due to lightning and power-line surges.

15. Overloading

Do not overload wall outlets, extension cords or integral convenience receptacles as this can result in a risk of fire or electric shock.

16. Object and Liquid Entry

Never push objects of any kind into this product through openings as they may touch dangerous voltage points or short-out parts that could result in a fire or electric shock. Never spill liquid of any kind on the product.

17. Inflammable and Explosive Substance

Avoid using this product where there are gases, and also where there are inflammable and explosive substances in the immediate vicinity.

18. Heavy Shock or Vibration

When carrying this product around, do not subject the product to heavy shock or vibration.

19. Servicing

Do not attempt to service this product yourself as opening or removing covers may expose you to dangerous voltage or other hazards. Refer all servicing to qualified service personnel.

20. Damage Requiring Service

Unplug this product from the wall outlet and refer servicing to qualified service personnel under the following conditions:

- a. When the power-supply cord or plug is damaged.
- b. If liquid has been spilled, or objects have fallen into the product.
- c. If the product has been exposed to rain or water.
- d. If the product does not operate normally by following the operating instructions. Adjust only those controls that are covered by the operating instructions as an improper adjustment of other controls may result in damage and will often require extensive work by a qualified technician to restore the product to its normal operation.
- e. If the product has been dropped or damaged in any way.
- f. When the product exhibits a distinct change in performance-this indicates a need for service.

21. Replacement Parts

When replacement parts are required, be sure the service technician has used replacement parts specified by the manufacturer or have the same characteristics as the original part.

Unauthorized substitutions may result in fire, electric shock, or other hazards.

22. Safety Check

Upon completion of any service or repairs to this product, ask the service technician to perform safety checks to determine that the product is in proper operating condition.

23. Wall or Ceiling Mounting

The product should be mounted to a wall or ceiling only as recommended by the manufacturer.

24. Heat

The product should be situated away from heat sources such as radiators, heat registers, stoves, or other products (including amplifiers) that produce heat.

WICHTIGE SICHERHEITS ANWEISUNGEN

1. Alle Anweisungen lesen

Vor Betrieb des Erzeugnisses sollten alle Sicherheits- und Bedienungsanleitungen gelesen werden.

2. Die Anweisungen aufbewahren

Die Sicherheits- und Bedienungsanleitungen sollten fünftigen Bezug aufbewahrt werden.

3. Warnungen beachten

Die Warnungen auf dem Erzeugnis und in den Bedienungsanleitungen sollten beachtet werden.

4. Anweisungen befolgen

Alle Bedienungsanleitung- und Verwendungsanweisungen sollten befolgt werden.

5. Reinigung

Den Stecker des Geräts vor Reinigung aus der Steckdose ziehen. Keine flüssigen Reinigungsmittel oder Aerosolreiniger verwenden. Zum Reinigen einen feuchten Lappen verwenden.

6. Zubehör

Nur vom Hersteller des Erzeugnisses empfohlenes Zubehör verwenden, da es sonst zu Störungen kommen kann.

7. Wasser und Feuchtigkeit

Dieses Erzeugnis nicht in der Nähe von Wasser verwenden - z.B. in der Nähe einer Badewanne, eines Waschbeckens, einer Küchenspüle, eines Waschzubers, in einem nassen Keller, in der Nähe eines Schwimmbeckens usw.

8. Aufstellung

Das Erzeugnis nicht auf einen unstabilen Wagen, Stand, Dreifuß, Träger oder Tisch stellen.

Das Erzeugnis kann sonst herunterfallen und ein Kind oder einen Erwachsenen schwer verletzen.

Außerdem kann das Gerät schwer beschädigt werden. Nur mit einem Wagen, Stand, Dreifuß, Träger oder Tisch verwenden, der vom Hersteller empfohlen oder mit dem Erzeugnis verkauft worden ist. Für jegliche Anbringung sollten die Anweisungen des Herstellers befolgt werden, und das vom Hersteller empfohlene Anbringungszubehör sollte verwendet werden.

9. Eine Kombination von Erzeugnis und Wagen sollte vorsichtig bewegt werden

Schneller Halt, übermäßige Krafteinwirkung und unebene Oberflächen können Umkippen der Kombination von Erzeugnis und Wagen verursachen.

10. Ventilation

Schlitze und Öffnungen im Gehäuse dienen der Ventilation. Sie sind für zuverlässigen Betrieb des Gerätes und Schutz vor Überhitzung erforderlich und dürfen nicht blockiert oder abgedeckt werden. Die Öffnungen sollten niemals dadurch blockiert werden, daß, das Gerät auf ein Bett, ein Sofa, einen Teppich oder eine ähnliche Oberfläche gestellt wird.

Das Gerät sollte nur dann in Einbauinstallation wie in einem Bücherschrank oder einem Gestell verwendet werden, wenn angemessene Ventilation vorgesehen ist bzw. Die Anweisungen des Herstellers befolgt worden sind.

11. Stromversorgung

Dieses Erzeugnis sollte nur an der auf dem Typenschild angegebenen Stromversorgungsart betrieben werden. Wenn Sie nicht sicher sind, was für eine Stromversorgung Sie haben, so wenden Sie sich bitte an Ihren Erzeugnishändler oder an das lokale Elektrizitätswerk. Beziehen Sie sich für Batteriebetrieb oder andere Stromquellen vorgesehene Erzeugnisse bitte auf die Bedienungsanleitungen.

12. Erdung oder Polarisierung

Dieses Erzeugnis ist mit einem Schutzkontaktstecker mit drei Leitern ausgerüstet, mit einem Erdungskontakt. Dieser Stecker paßt nur in eine Schuko-Steckdose. Dies ist eine Sicherheitsmaßnahme. Wenn Sie den Stecker nicht in die Steckdose stecken können, so wenden Sie sich bitte an Ihren Elektriker, damit er die veraltete Schutz des Schutzkontaktsteckers unwirksam macht.

13. Netzkabelschutz

Netzkabel sollten so verlegt werden, daß möglichst nicht darauf getreten wird und daß sie nicht eingeklemmt werden, mit besonderer Beachtung der Kabel an Stackern, Verlängerungskabeln und dem Austritt des Kabels aus dem Erzeugnis.

14. Blitzschlag

Für zusätzlichen Schutz des Erzeugnisses während eines Gewitters oder bei Nichtverwendung für lange Zeit den Stecker aus der Steckdose ziehen. Dies verhindert Beschädigung durch Blitzschlag und Netzspannungsschläge.

15. Überlastung

Wandsteckdosen, Verlängerungskabel und eingebaute Bequemlichkeitssteckdosen nicht überlasten, da dies Feuer oder elektrischen Schlag verursachen kann.

16. Eindringen von Fremdkörpern und Flüssigkeit

Niemals Objekte irgendwelcher Art durch die Öffnungen in das Gerät schieben, da diese unter hoher Spannung stehende Teile berühren oder kurzschließen können, wodurch es zu Feuer oder elektrischem Schlag kommen kann. Niemals Flüssigkeiten irgendwelcher Art auf das Erzeugnis verschütten.

17. Entflammare und explosive Substanzen

Vermeiden Sie Verwendung dieses Erzeugnisses an Orten mit Gasen bzw. entflammaren oder explosiven Substanzen in der direkten Umgebung.

18. Starke stöße oder Vibrationen

Setzen Sie das Erzeugnis beim Transport nicht starken Stößen oder Vibrationen aus.

19. Wartung

Versuchen Sie nicht, dieses Erzeugnis Selbst zu warten, da Sie sich durch Öffnen bzw. Entfernen von Abdeckungen hohen Spannungen und sonstigen Gefährdungen aussetzen können.

Beziehen Sie sich für jegliche Wartung auf qualifiziertes Wartungspersonal.

20. Beschädigung, die Wartung erfordert

Ziehen Sie den Stecker dieses Erzeugnisses aus der Steckdose und wenden Sie sich an qualifiziertes Wartungspersonal, wenn eine der folgenden Bedingungen vorliegt:

- a. Wenn das Netzkabel oder der Stecker beschädigt ist.
- b. Bei Eindringen von Flüssigkeit oder Fremdkörpern in das Gerät.
- c. Wenn das Erzeugnis Regen oder Wasser ausgesetzt worden ist.
- d. Wenn das Erzeugnis bei Befolgen der Bedienungsanleitungen nicht normal funktioniert.

Nur die Regelelemente verstellen, die in den Bedienungsanleitungen behandelt werden, da unangemessene Einstellung anderer Regelelemente Beschädigung verursachen kann und oft beträchtliche Arbeit durch einen qualifizierten Techniker erfordert, um das Erzeugnis wieder, zu normalem Betrieb zurückzubringen.

- e. Wenn das Erzeugnis fallen gelassen oder beschädigt worden ist.
- f. Wenn das Erzeugnis eine klare Änderung in der Leistung zeigt-dies weist darauf hin, daß Wartung erforderlich ist.

21. Ersatzteile

Wenn Ersatzteile erforderlich sind, darauf achten, daß der Wartungstechniker nur die vom Hersteller festgelegten Ersatzteile oder Teile mit den gleichen Charakteristiken wie die ursprünglichen Teile verwendet. Unautorisierte Ersatzteile können Feuer, elektrischen Schlag oder sonstige Gefährdungen verursachen.

22. Sicherheitsprüfung

Bitten Sie den Wartungstechniker nach der Vollendung von Wartung oder Reparaturarbeiten an diesem Erzeugnis um die Durchführung von Sicherheitsprüfungen, um zu bestimmen, daß das Erzeugnis im angemessenen Betriebszustand ist.

23. Anbringung an der Wand oder an der Decke

Das Erzeugnis sollte nur entsprechend den Empfehlungen des Herstellers an einer Wand oder an der Decke angebracht werden.

24. Wärme

Das Erzeugnis sollte fern von Wärmequellen wie Radiatoren, Heizwiderständen, Öfen und anderen Wärme erzeugenden Erzeugnissen (einschließlich Verstärkern) aufgestellt werden.

MISES EN GARDE IMPORTANTES

1. Lire les instructions

Lire toutes les instructions de sécurité et de fonctionnement avant de faire fonctionner l'appareil.

2. Conserver ces instructions

Conserver les instructions de sécurité et de fonctionnement à des fins de référence ultérieure.

3. Tenir compte des avertissements

Tous les avertissements qui figurent sur l'appareil et dans le mode d'emploi devront être respectés.

4. Observer les instructions

Observer toutes les instructions de fonctionnement et d'utilisation.

5. Nettoyage

Avant de procéder au nettoyage, débrancher l'appareil de la prise secteur. Ne pas utiliser de produits de nettoyage liquides ou en aérosol.

Nettoyer l'appareil avec un chiffon humide.

6. Fixations

Ne pas utiliser de fixations non recommandées par le fabricant de l'appareil car elles pourraient être source de danger.

7. Eau et humidité

Ne pas utiliser l'appareil à proximité d'eau - par exemple près d'une baignoire, d'un lavabo, d'un évier ou d'un bac à lessive, dans un sous-sol humide, ou près d'une piscine, etc.

8. Accessoires

Ne pas placer l'appareil sur un chariot, un socle, un pied, un support ou une table instables. L'appareil pourrait tomber, blessant grièvement des enfants ou des adultes, et étant sérieusement endommagé.

Utiliser exclusivement le chariot, le socle, le pied, le support ou la table recommandés par le fabricant, ou vendus avec l'appareil. Pour tout montage de l'appareil, respecter les instructions du fabricant, et utiliser à cette fin l'accessoire de montage recommandé par le fabricant.

9. L'appareil monté sur son chariot devra être déplacé avec précaution

Des arrêts brusques, une force excessive et des surfaces irrégulières pourraient provoquer le renversement de l'ensemble appareil-chariot.

10. Ventilation

Les fentes et les ouvertures du coffret sont prévues pour la ventilation ainsi que pour garantir un fonctionnement en toute sécurité de l'appareil et le protéger de toute surchauffe, et ces ouvertures ne devront donc être ni obstruées ni recouvertes. Ne jamais obstruer les ouvertures en plaçant l'appareil sur un lit, un sofa, un tapis ou toute surface similaire. Ne jamais placer l'appareil dans un support confiné, par exemple une bibliothèque ou une étagère, sans ventilation suffisante ou sans respecter les instructions du fabricant.

11. Sources d'alimentation

L'appareil devra être alimenté exclusivement sur le type d'alimentation indiqué sur l'étiquette signalétique. Si l'on n'est pas sûr du type d'alimentation du local, consulter le revendeur de l'appareil ou la compagnie d'électricité locale. Pour les appareils qui fonctionnent sur batterie ou sur d'autres sources, voir le mode d'emploi.

12. Mise à la terre ou polarisation

L'appareil est doté d'une fiche trifilaire avec mise à la terre, dont la troisième broche assure la mise à la terre. Cette fiche ne rentrera que dans les prises trifilaires de mise à la terre. Ceci est une mesure de sécurité. Si la fiche ne rentre pas dans la prise, faire remplacer la prise défectueuse par un électricien.

Ne pas rendre vaine la mesure de sécurité assurée par cette prise avec mise à la terre.

13. Protection du cordon d'alimentation

Acheminer les cordons d'alimentation de façon qu'on ne risque pas de marcher dessus ou de les coincer sous un objet placé dessus ou contre eux.

Faire particulièrement attention aux fiches des cordons, à la proximité des prises, et à l'endroit où ils ressortent de l'appareil.

14. Foudre

Pour renforcer la protection de l'appareil pendant un orage, ou si l'on s'en éloigne ou qu'on reste longtemps sans l'utiliser, le débrancher de la source d'alimentation. Ceci permettra d'éviter tout dommage de l'appareil dû à la foudre et aux surtensions de ligne.

15. Surcharge

Ne pas surcharger les prises, rallonges et prises multiples car cela pourrait entraîner un risque de feu ou de choc électrique.

16. Pénétration d'objets et de liquides

Ne jamais enfoncer d'objets d'aucune sorte dans les ouvertures de l'appareil car ils pourraient toucher des points de tension dangereuse ou court-circuiter des pièces, ce qui pourrait provoquer un feu ou un choc électrique. Ne jamais renverser de liquide d'aucune sorte sur l'appareil.

17. Substances inflammables et explosives

Eviter d'utiliser l'appareil en présence de gaz, ainsi qu'à proximité immédiate de substances inflammables et explosives.

18. Chocs ou vibrations violents

Lorsqu'on transporte l'appareil, ne pas le soumettre à des chocs ou des vibrations violents.

19. Réparations

Ne pas tenter de réparer l'appareil soi-même car le fait d'ouvrir ou de retirer les caches risque d'exposer l'utilisateur à des tensions dangereuses notamment. Confier toute réparation à un personnel qualifié.

20. Dommages nécessitant réparations

Débrancher l'appareil de la source d'alimentation et confier les réparations à un personnel qualifié dans les cas suivants:

- a. Lorsque le cordon d'alimentation ou sa fiche sont endommagés
- b. Si du liquide s'est renversé sur l'appareil ou que des objets sont tombés dedans
- c. Si l'appareil a été exposé à la pluie ou à l'eau.
- d. Si l'appareil ne fonctionne pas normalement lorsqu'on observe les instructions d'utilisation.

Ne régler que les commandes couvertes par le mode d'emploi ; en effet, un réglage incorrect des autres commandes pourrait entraîner des dommages et nécessiteront souvent des travaux de réparation coûteux par un technicien qualifié pour remettre l'appareil en état de marche.

- e. Si l'appareil est tombé ou qu'il a été endommagé.
- f. Si l'appareil affiche une nette modification de ses performances, cela signifie qu'il a besoin d'être réparé.

21. Pièces de rechange

Si l'on a besoin de pièces de rechange, veiller à ce que le technicien de réparation utilise exclusivement les pièces de rechange spécifiées par le fabricant ou des pièces ayant les mêmes caractéristiques que les pièces d'origine. Les pièces de rechange non autorisées risquent de provoquer un feu, un choc électrique et autres dangers.

22. Vérification de sécurité

Après tout travail d'entretien ou de réparation de l'appareil, demander au technicien de réparation d'effectuer les vérifications de sécurité pour s'assurer que l'appareil est en bon état de marche.

23. Montage au mur ou au plafond

L'appareil ne pourra être monté au mur ou au plafond que de la manière recommandée par le fabricant.

24. Chaleur

Eloigner l'appareil des sources de chaleur, telles que radiateurs, appareils de chauffage, cuisinières, et de tout produit engendrant de la chaleur (y compris les amplificateurs).

IMPORTANT NOTICE

USA

These products have been tested and found to comply with the limits for a Class A digital device, pursuant to Part 15 of the FCC Rules. These limits are designed to provide reasonable protection against harmful interference when the equipment is operated in a commercial environment. This equipment generates, uses, and can radiate radio frequency energy and, if not installed and used in accordance with the instruction manual, may cause harmful interference to radio communications. Operation of this product in a residential area is likely to cause harmful interference in which case the user will be required to correct the interference at his own expense.

WARNING

Changes or modifications not expressly approved by Hitachi Kokusai Electric Ltd. responsible for compliance could void the user's authority to operate the equipment.

For Canada

This product does not exceed the class A/class B limits for radio noise emissions from digital apparatus as set out in the radio interference regulations.

Le présent appareil n'émet pas de bruits radioélectriques dépassant les limites applicable aux appareils numériques de classe A prescrites dans le règlement sur le brouillage radioélectrique édicté par le ministère des communications du Canada.

This page show the **declaration of conformity** for CE.
That reference number is the **KV-0366**, and report number is the **V3T-0164**.

Ref.No.KV-0366

Declaration of Conformity

Manufacturer's Name: Hitachi Kokusai Electric, Inc.
Manufacturer's Address: 4-14-1 Sotokanda, Chiyoda-ku,
Tokyo 101-8980, Japan

**Representative(s) Address
in the EU:** Hitachi Kokusai Electric Europe GmbH
Siemens Strasse 9, D-63263 Neu-Isenburg,
Germany

declares, that the product:

Product Name: 3CCD Camera
Model Number(s): HV-F202SCL

conforms to the following Standards:

EMC: EN 61000-6-3/2007
EN 61000-6-1/2007

Supplementary Information:

"The product complies with the requirements of the Low Voltage
Directive 2006/95/EC and the EMC Directive 2004/108/EC."

Signature:



K. Enomoto
Senior Manager
Quality Assurance Department II
Hitachi Kokusai Electric Inc.

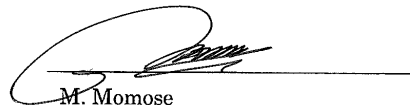

M. Momose
Managing Director
Hitachi Kokusai Electric Europe GmbH

Date: 16th Apr. ,2011

V3T-0164

Note : This product using the following equipment satisfied the CE standard.
The camera cable by shield type (C-201KSS).
Mini-CameraLink cable (C-201SCL).
Clamp filters (ZCAT 2035-0930A: TDK) at both ends (camera and video processor ends).

China RoHS

The following statement is related to the regulation on “ Measures for the Administration of the control of Pollution by Electronic Information Products “ , known as “ China RoHS “.

The table shows contained Hazardous Substances in this camera.

说明书（环境方面：补充资料）

对象产品：彩色摄像机

1. 电子产品污染控制标志



此标志是根据 2006 年 2 月 28 日公布的《电子信息产品污染控制管理办法》以及 SJ/T11364-2006《电子信息产品污染控制标识要求》而制定的，是用来表示适用于在中华人民共和国流通的电子信息产品的环保使用期限。

只要遵守此类产品的安全事项以及使用上应注意的问题，从制造日起到此年限内，不会发生产品中的有害物质外泄、突变等，不会对环境、人体以及财产产生严重影响。同时，此年限是除去必须定期交换的保守部品的，是其他产品的环保使用期限。

产品在正常情况下使用完毕要废弃时，请遵守各地区对电子信息产品的回收·再利用的相关各项法律、法规。

另外，从第三者处转买的情况下即使在本期限内也视为失去效力。

2. 产品中有毒有害物质或元素的名称及含量

	部件名称	有毒有害物质或元素					
		铅 (Pb)	水银 (Hg)	镉 (Cd)	六价铬 (Cr(VI))	多溴联苯 (PBB)	多溴二苯醚 (PBDE)
1	主机	×	○	×	○	○	○

○：表示该有毒有害物质在该部件所有均质材料中的含量均在 SJ/T11363-2006 标准规定的限量要求以下。
×：表示该有毒有害物质至少在该部件的某一均材料中的含量超出 SJ/T11363-2006 标准规定的限量要求。

Phenomena inherent to CCD imaging device

The following phenomena are inherent to a charge coupled device imaging element and do not indicate malfunction.

1) Smear and blooming

Vertical bands are visible when a strong light enters the scene. Adjust the camera aiming direction carefully to avoid strong direct or reflected light.

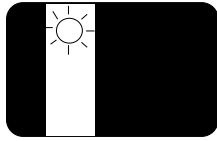

2) Fixed pattern noise

High ambient temperature can cause fixed pattern noise to appear throughout the scene.

3) Moire

Interaction between patterns can produce an additional "phantom" pattern to appear. The CCD picture elements (pixels) are arranged in a pattern, which can interact with a pattern in the scene (e.g., a performer wearing a finely striped necktie) to result in a Moire pattern. The effect should be considered when selecting costumes, props and other scene elements.

4) Ghosting

Strong direct or reflected light near an object of interest can cause ghosting of the object to appear in the picture. The effect is more obtrusive with certain iris settings and lens types. Select the scene layout and camera pointing direction carefully in order to avoid this effect.

5) White spot

Imperceptible white spots may rarely come up on the screen due to cosmic rays and so on. It becomes easy to appear when the sensitivity of the camera is raised in the operation at the high temperature.

Combination with a microscope

The following phenomena occur by combining a camera and optical apparatus and do not indicate malfunction.

1) Vignetting

Depending on a microscope, light may enter into a camera at an angle larger than a lens for large view reservation, and the portion which becomes dark at the screen upper and lower ends may occur. This phenomenon can be reduced by the shading compensation function of a camera. However, this phenomenon cannot be rectified completely. When accessories, such as a relay lens, are prepared for the microscope, vignetting may improve optically.

Operating considerations Notes to users

1. Important safety notes

- Please supply the direct current 12V of the camera input power supply within the range of 11 to 13V
- Time will be needed for about four seconds by the time the camera works normally after turning on the power supply.
- Observe that flammable objects, water or metal do not enter the camera interior. These may lead to failure or accident.
- Do not modify the camera or use the camera with external covers removed. These may cause failure, void any warranties and pose a safety hazard.
- Stop using the camera at the approach of electrical storm (thunder audible). Protect the camera from rain if using it outdoors.
- In event the camera shows any abnormality, switch off the camera and disconnect the power cord. Contact a Hitachi Denshi service representative.

2. Handling

- Do not attempt to remove cover.
- When installing or removing a lens, be sure to use care that water or dust does not enter the inside of the camera.

3. Installing and storage

Avoid installing or storing the camera in the following environments.

- Environments exposed to direct sunlight, rain or snow.
- Environments where combustible or corrosive gas exists.
- Excessively warm or cold environment (Operating ambient temperature: -10 to 50°C).
- Humid or dusty environment.
- Place subjected to excessive vibration or shock.
- Environment exposed to strong electric or magnetic field.
- Do not aim the camera lens at the sun.
- Do not shoot strong light.

When such a scene is shot, vertical trailing will appear. However, this is not due to failure. In case strong light enters camera through the lens, partial deterioration in picture quality will result.

4. To obtain stable performance for long time

When the camera is used continuously for long time under high ambient temperature, the inside electrical parts become deteriorated, resulting in shortening its life. To use the camera continuously for long time, the highest temperature must be below 40°C.

5. Connectors

Confirm the power is off before connecting or disconnecting a signal cable. Grasp connectors by the body, not the attached wires.

6. Cleaning

- Use a blower or a lens brush to remove dusts on the lens or the optical filter.
- Wipe dirt on the case off with dry soft cloth. If dirt is hardened, wipe them off with cloth moistened with neutral detergent liquid; wipe the cover with dry cloth.
- Do not use benzene, thinner, alcohol, liquid cleaner or spray-type cleaner.
- In event dust or other debris is lodged between the CCD and optical filter, consult dealer for cleaning by an optical technician.

Table of Contents

1. Overview	1.
2. Standard Composition	1
3. Features	1
4. System example	1
5. Section name and functions	2
6. Camera mounting	2
7. Lens	2
8. Connector	3
9. Functions and operations	5
10. Remote control	10
11. Command list	17
12. CameraLink output timing chart	21
13. Trigger operation and timing chart	25
14. Input / Output signal	27
15. Spectral response	27
16. Specifications	28
17. Dimensions	29

Overview

HV-F202SCL is high precision 3CCD progressive scan color camera, which has single chip digital processing LSI, a C mount prism, 1/1.8 inch 2,000,000 pixels square CCD and CameraLink interface.

Standard composition

Check when unpacking

Camera 1
 Installation guide 1
 Plug for DC IN/SYNC connector (HR10A-10P-12S) 1

Optional accessories

- (1) 12 pin plug HR10A-10P-12S(01)
 (2) Junction box JU-F30/JC-100
 (3) Tripod adaptor TA-F202
 (4) Mini-CameraLink cable
 (CameraLink standard conformity)

(5) Cameracable

	Molded type	Shield type
2m	C-201KSM	C-201KSS
5m	C-501KSM	C-501KSS
10m	C-102KSM	C-102KSS

In the CE Marking region, use the shield type and attach clamp filter (ZCAT 2035-0930A: TDK) at both ends (camera and video processor ends). Refer to System example.

Note : When not using the specified junction box, Mini-CameraLink cable, camera cable and clamp filter, malfunctions may be caused.

Features

•High resolution and color fidelity

The 1/1.8-inch 2.02 million pixels square lattices progressive scan CCD and dichroic prism for RGB color achieves a high resolution of UXGA picture and good color reproduction.

•Small and lightweight

The small SDR connector for digital output allows the camera size and mass to be drastically reduced to 55(W) x 55(H) x 89(D) mm / approx. 350g.

•Various picture quality enhancement

Independent size color masking is the Hitachi innovation for optimizing color balance. Saturation and hue of 6 colors (Red, Green, Blue, Cyan, Magenta and Yellow) can be adjusted independently to deliver the best color in image capture, microscope and other applications.

In-out gradation control can be arbitrarily adjusted by using LUT.

•Auto shading correction

Color shading due to aberration of the lens is automatically compensated or reduced.

•Versatile CCD drive functions

Video frame capture on demand using external trigger signal

Long integration mode (max. 10 seconds)

Variable shutter mode (min. 1/100,000 second)

Auto electronic shutter mode

System example

HV-F202SCL connects to frame grabber board using Mini-CameraLink cable.

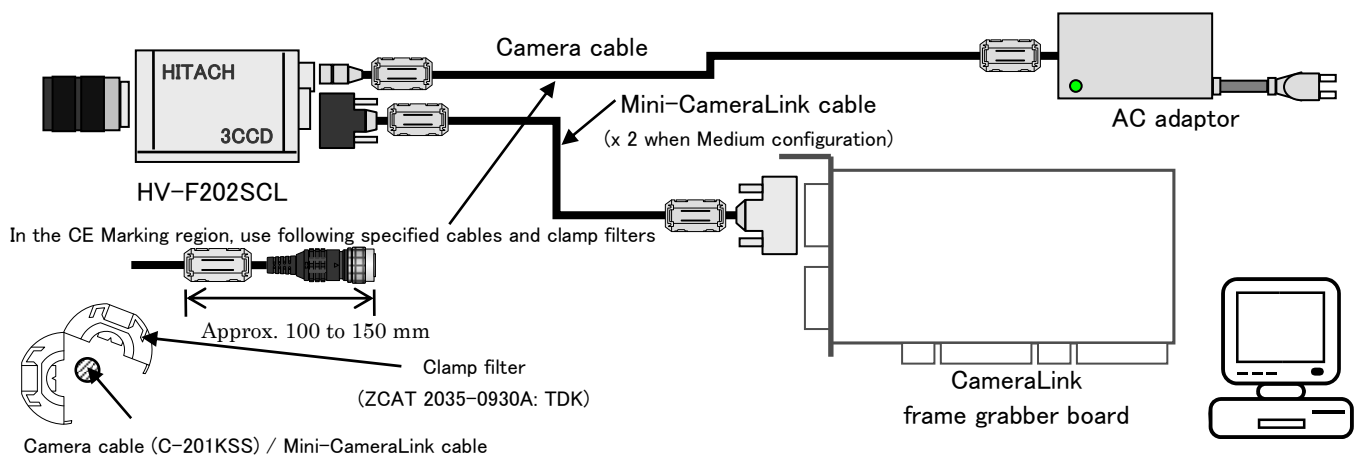

Section name and functions

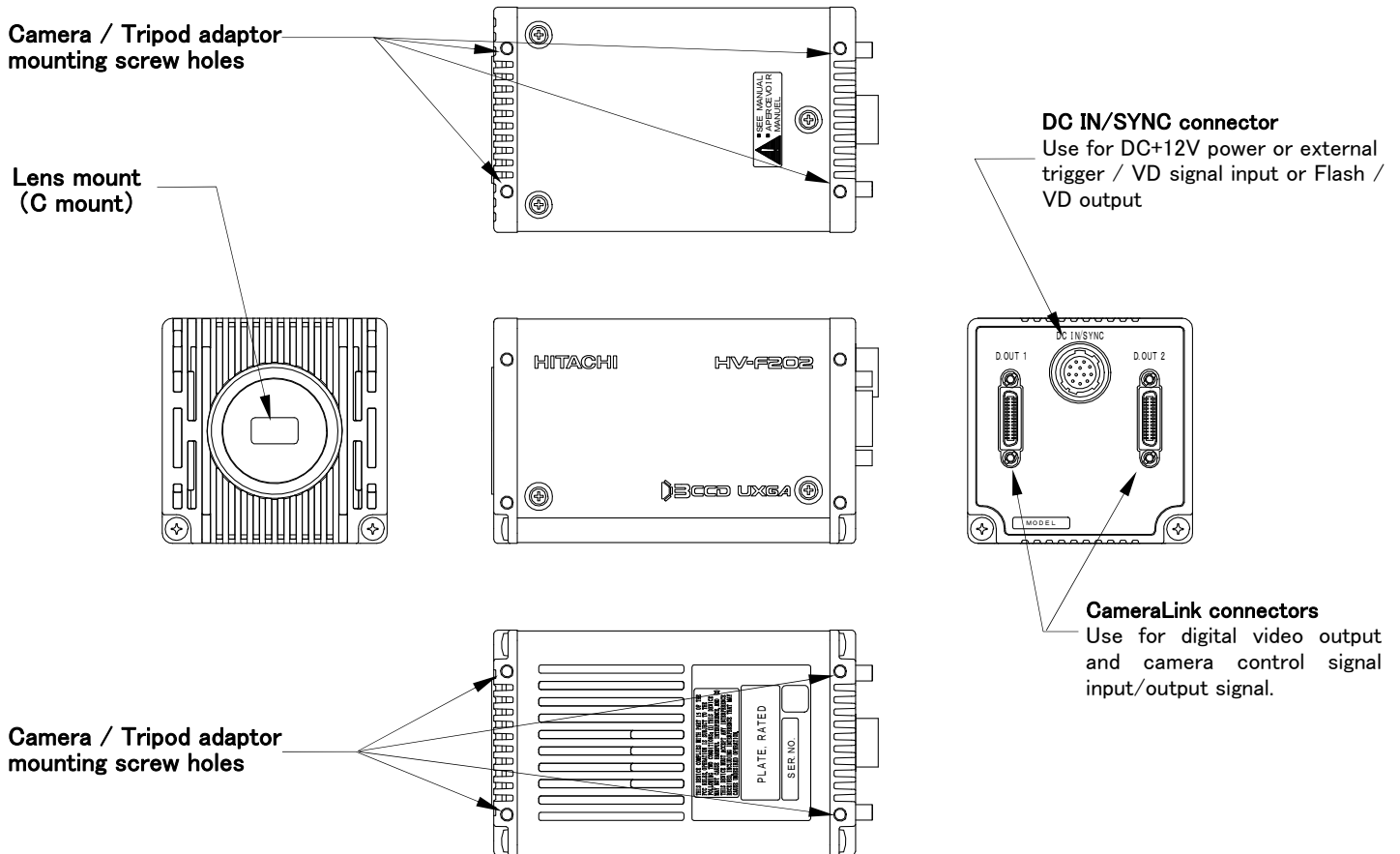

Camera mounting

Attached optional accessory the tripod adaptor "TA-F202", mount the camera to a tripod or mounting bracket.

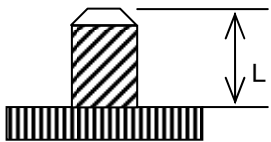

Screw type: U1/4-20

Length L = 4 to 5.5mm

Screws longer than 5.5 mm can cause internal damage, while less than 4 mm prevents secure fastening and risks dropping to cause damage and injury.

Lens

CAUTION

Observe the dimensions of the lens mounting selection as illustrated at the right.

If the dimensions are not observed, do not use such a lens, because the lens and the camera will be damaged.

Selecting a lens

The proper lens is important for obtaining adequate performance from the camera. Especially in the case of a three elements CCD system C mount camera, the lens incidence and exit distances are important. If separation is too short, color irregularity is apt to occur at the top and bottom of the image.

Conversely if too long, where the lens iris is a nearly fully open, resolution is impaired, while shading and flare can seriously detract from image quality. When using 3 CCD color system camera, it is also recommended to use a lens designed for this purpose.

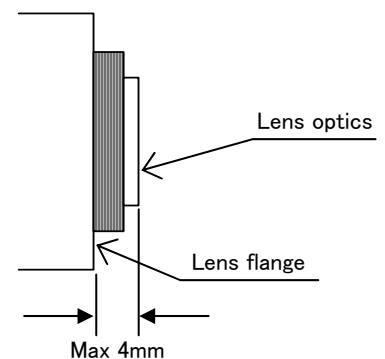

Connector

1. CameraLink connector

(a) Interrelation between number of DATA bit and number of used connector

	Number of Data bits	D.OUT1	D.OUT2	
1	24bit (R: 8bit G: 8bit B: 8bit)	O	-	O: Use
2	30bit (R: 10bit G: 10bit B: 10bit)	O	O	-: Not use
3	36bit (R: 12bit G: 12bit B: 12bit)	O	O	

(b) Signal connection of DIGITAL OUT connector

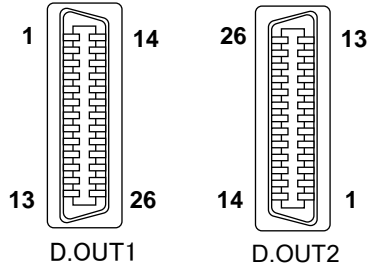

D.OUT 1 (Connector 1)

Pin No.	Signal	Pin No.	Signal
1	GND	14	GND
2	TXOUT 0 (-)	15	TXOUT 0 (+)
3	TXOUT 1 (-)	16	TXOUT 1 (+)
4	TXOUT 2 (-)	17	TXOUT 2 (+)
5	TXCLKOUT (-)	18	TXCLKOUT (+)
6	TXOUT 3 (-)	19	TXOUT 3 (+)
7	RX (+) [SERTC (+)]	20	RX (-) [SERTC (-)]
8	TX (-) [SERTFG (-)]	21	TX (+) [SERTFG (+)]
9	TRIG/VD (-) [CC1 (-)]	22	TRIG/VD (+) [CC1 (+)]
10	N.U. [CC2 (+)]	23	N.U. [CC2 (-)]
11	N.U. [CC3 (-)]	24	N.U. [CC3 (+)]
12	N.U. [CC4 (+)]	25	N.U. [CC4 (-)]
13	GND	26	GND

D.OUT 2 (Connector 2: used for Medium configuration)

Pin No.	Signal	Pin No.	Signal
1	GND	14	GND
2	TYOUT 0 (-)	15	TYOUT 0 (+)
3	TYOUT 1 (-)	16	TYOUT 1 (+)
4	TYOUT 2 (-)	17	TYOUT 2 (+)
5	TYCLKOUT (-)	18	TYCLKOUT (+)
6	TYOUT 3 (-)	19	TYOUT 3 (+)
7	N.U.	20	N.U.
8	N.U.	21	N.U.
9	N.U.	22	N.U.
10	N.U.	23	N.U.
11	N.U.	24	N.U.
12	N.U.	25	N.U.
13	GND	26	GND

SDR connector (3M) or equivalent

N.U.: Not used

- The digital out cable should be comprised of a twisted pair of wires having 100Ω characteristic impedance and an outer sheath shield type conductor.
- Connect the shield (ground) of the digital out cable to the ground terminal of the video equipment, frame grabber, etc.
- TX: Transmit data from camera to machine
- RX: Transmit data from machine to camera

(Note) Please do not unplug and insert cable (digital out cable) with a power supplied to a camera.

Install clamp filter (ZCAT2035-0930A: TDK) at both ends (camera and video processor ends) in the CE marking legion.

2. DCIN/SYNC connector

PIN NO.	Signal	PIN NO.	Signal
1	GND (+12V)	7	TRIG-A / VD (H) IN
2	+12V	8	TRIG-B (C) IN
3	GND	9	TRIG-B (H) IN
4	N.C.	10	FLASH / VD (H) OUT
5	FLASH / VD (C) OUT	11	N.C.
6	N.C.	12	TRIG-A / VD (C) IN

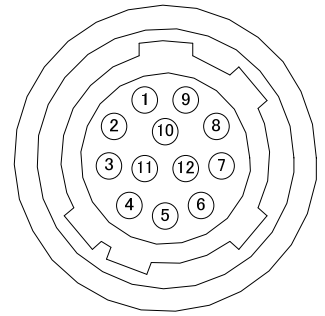

Connector (camera side) : SANWOO SHN-10-12 (RPCB) or equivalent
 Plug (matching cable plug: HR10A-10P-12S(01) HIROSE or equivalent

TRIG-A/VD and TRIG-B are input using digital isolation, and FLASH/VD OUT is output by digital Isolation, therefore 8/12/5 pin are isolate from 1/3 pin.

When the system requirement should be connect to GND and that doesn't need isolation, please connect 8/12/5 pin to 1/3 pin.

(Note) Please do not unplug and insert cable (camera cable) with a power supplied to a camera.

Install clamp filter(ZCAT 2035-0930A: TDK) at both ends (camera and video processor ends) in the CE marking region.

Please do not input any signal to N.U. pin because machine may break down.

Functions and operations

Various mode setup and adjustment of HV-F202SCL are performed by the remote control via CameraLink.

Operation and adjustment way of function utilized are described below.

See "Remote control" (page 10 to 16) and "Command list" (page 17 to 20) about communication method of each command.

(1) TRIGGER : Setting about external trigger

•MODE : Selection of mode

OFF (Factory setting) : Trigger mode set to OFF (normal mode).

FIXED SHUTTER : Set to Fixed shutter mode.

ONE TRIGGER : Set to ONE trigger mode.

VD CONTROL : Set to VD reset mode.

•POLARITY : Selection of trigger polarity

POSITIVE (Factory setting): Input polarity HIGH is made into trigger signal.

NEGATIVE : Input polarity LOW is made into trigger signal.

•SOURCE : Selection of trigger source

CL-CC1 (Factory setting) : Input trigger signal from CameraLink signal CC1 (see page 4 "Connector").

12pin : Input trigger signal from 7 pin of 12 pin DCIN/SYNC connector.

* See "Trigger operation and timing chart" (page 25 to 27).

(2) SHUTTER : Setting of electronic shutter

OFF (Factory setting) : Shutter operation set to OFF (normal shutter).

1/30, 1/60, 1/100,

1/250, 1/1000, 1/2000,

1/10000, 1/50000 second : Set to setting shutter speed (PRESET shutter).

VARIABLE : Set to shutter speed from 10 second to 1/100000 second (VARIABLE shutter).

-VARIABLE VALUE- : Setting speed of VARIABLE shutter.

10 to 1/100000 second : Electronic shutter can be set in the range of 10 to 1/100,000 second in 1536 steps
(Factory setting is 1/30)

Shutter speed setting value can be derived as follows. (*ShutterSpeed*: μ second)

a) Setting value xyy obtained from exposure time.

$$X = \text{int}(\log(\text{ShutterSpeed})) - 1$$

$$YY = \text{int}\left(\left(\frac{\text{ShutterSpeed}}{10^{X+1}} - 1\right) \times \frac{100_{16}}{9}\right)$$

b) Exposure time obtained from setting value.

$$\text{ShutterSpeed} = 10^{X+1} \times \left(1 + \frac{YY_{16}}{100_{16}} \times 9\right) [\mu \text{sec}]$$

Ex.1 Exposure time = setting value nnn to obtain 1/125 second (= 8000 μ second).

$$X = \text{int}(\log(8000)) - 1$$

$$= 2$$

$$YY = \text{int}\left(\left(\frac{8000}{10^{2+1}} - 1\right) \times \frac{100_{16}}{9}\right)$$

$$= \text{int}\left(7 \times \frac{100_{16}}{9}\right)$$

$$= C7_{16}$$

$$\therefore \text{XYY} = 2C7_{16}$$

Ex.2 Setting value 25Dh that produces 1/234.22 second exposure time.

$$\text{ShutterSpeed} = 10^{2+1} \times \left(1 + \frac{5D_{16}}{100_{16}} \times 9\right)$$

$$= 4269.53 [\mu \text{sec}]$$

$$= \frac{1}{234.22} [\text{sec}]$$

(3) GAIN LEVEL : Setting of electrical sensitivity

-LEVEL- : Adjust MANUAL gain level

0 (Factory setting) to 341 : Set MANUAL gain when AGC is OFF.
Adjustable from 0 to 12dB in 342 steps.

(4) BRIGHTNESS : Adjust offset level

0 to 255 : Set in 256 steps. (Factory setting:128)

(5) GAMMA : Setting of gamma correction

-MODE- : Selection of mode

OFF (Factory setting) : Not perform gamma correction.

ON : Adjust the detail gamma according to setting value.

-LEVEL- : Adjust gamma correction

0 (Factory setting) to 255 : Set gamma curve in 256 steps.

(6) KNEE : Setting of KNEE

***This function is enable when LUT MODE is OFF**

-MODE- : Selection of mode

OFF (Factory setting) : Not perform knee.

ON : Knee function provides natural gradation in bright portions.

-KNEE POINT- : Adjust knee point

0 (Factory setting) to 32 : Setting value toward 0 side increase start level of knee and 32 side decrease start level of knee.

-KNEE SLOPE- : Adjust knee slope

0 (Factory setting) to 159 : Setting value toward 0 side intensify effective of knee and 159 side weaken effective of knee.

(7) LUT : Setting of Look Up Table

*** This function is enable when LUT MODE is OFF**

-MODE- : Selection of mode

OFF (Factory setting) : Not apply LUT for the image.

ON : The output image Adjusted LUT Knee function provides natural gradation in bright portions.

-TABLE R [n]- : 256 LUTs for Red (n is table number and input)

0 to 255 : Output to input (Factory setting is table number).

-TABLE G [n]- : 256 LUTs for Green (n is table number and input)

0 to 255 : Output to input (Factory setting is table number).

-TABLE B [n]- : 256 LUTs for Blue (n is table number and input)

0 to 255 : Output to input (Factory setting is table number).

(8) SHARPNESS : Setting of object contour correction

-MODE- : Selection of mode

OFF (Factory setting) : Not perform contour correction.

ON : Perform contour correction according to setting value.

-LEVEL- : Adjust sharpness level

0 to 255 : Setting value toward 0 side reduces correction for soft contours and 255 side increase correction for sharper contours (Factory setting: 128).

(9) ALC : Setting of Auto Level Control of video level

-MODE- : Selection of mode

OFF (Factory setting) : AGC is set to OFF (MANUAL gain). AES is set to OFF (NORMAL shutter).

AGC : AES is set to OFF and video level is automatically adjusted in the range of 0 to 12dB.

AES : Shutter is automatically adjusted to light source brightness.

AGC & AES : Both AGC and AES are set to ON.

-VIDEO LEVEL- : Setting of video level when AGC or AES is ON

0 to 255 : Setting value toward 0 side decrease convergence level and 255 side increase convergence level.
(Factory setting:128)

(10) WHITE BALANCE : Setting of white balance.

-MODE- : Selection of mode

ATW : White balance is adjusted in real time (automatic tracking).

MANUAL (Factory setting): White balance is adjusted manually by adjusting R, G and B GAIN.

ADJUST : State for automatic white balance adjustment.

-R GAIN- : Adjust red gain

0 to 255 : Red gain is reduced at 0 side and raised at 255 side (Factory setting is 128).

-B GAIN- : Adjust blue gain

0 to 255 : Blue gain is reduced at 0 side and raised at 255 side (Factory setting is 128).

(11) MASKING : Setting of 6 vector independent making (primary color R G B and complementary color Ye Cy Mg saturation and hue can be separately varied).

-MODE- : Selection of mode

OFF (Factory setting) : Not use masking functions.

ON : Use masking functions.

-R SATURATION- : Adjust red saturation

0 (Factory setting) to 255 : Adjust red saturation in 256 steps.

-R HUE- : Adjust red hue

0 (Factory setting) to 255 : Red come near to yellow at 0 side and come near to cyan at 255 side.

-Cy SATURATION- : Adjust cyan saturation

0 (Factory setting) to 255 : Adjust red saturation in 256 steps.

-Cy HUE- : Adjust cyan hue

0 (Factory setting) to 255 : Cyan come near to red at 0 side and come near to green at 255 side.

-G SATURATION- : Adjust green saturation

0 (Factory setting) to 255 : Adjust red saturation in 256 steps.

-G HUE- : Adjust green hue

0 (Factory setting) to 255 : Green come near to cyan at 0 side and come near to magenta at 255 side.

-Mg SATURATION- : Adjust magenta saturation

0 (Factory setting) to 255 : Adjust red saturation in 256 steps.

-Mg HUE- : Adjust magenta hue

0 (Factory setting) to 255 : Magenta come near to green at 0 side and come near to blue at 255 side.

-B SATURATION- : Adjust blue saturation

0 (Factory setting) to 255 : Adjust red saturation in 256 steps.

-B HUE- : Adjust blue hue

0 (Factory setting) to 255 : Blue come near to magenta at 0 side and come near to yellow at 255 side.

-Ye SATURATION- : Adjust yellow saturation

0 (Factory setting) to 255 : Adjust red saturation in 256 steps.

-Ye HUE- : Adjust yellow hue

0 (Factory setting) to 255 : Yellow come near to blue at 0 side and come near to red at 255 side.

(12) PAINT BLACK : Setting of paint black (color level of R, G, and B can be separately varied).

-MODE- : Selection of mode

OFF (Factory setting) : Not use paint black functions.

ON : Use paint black functions.

-RED- : Adjust red color level

0 (Factory setting) to 255 : Adjust red color level in 256 steps.

-GRREN- : Adjust green color level

0 (Factory setting) to 255 : Adjust green color level in 256 steps.

-BLUE- : Adjust blue color level

0 (Factory setting) to 255 : Adjust blue color level in 256 steps.

(13) WHITE SHADING : Setting of white shading correction.

Color shading may occur in the vertical direction on screen due to any characteristic of lens. This camera is equipped with a function for correcting color shading automatically.

-MODE- : Selection of mode

OFF (Factory setting) : Not perform white shading correction.

ON : Perform white shading correction.

-ADJUST- : AUTO SHADING (Correct white shading)

- i . Provide a proper aperture value of lens.
- ii . Take an white image fully on screen. At this step, take care so that uneven brightness will not occur in the vertical and horizontal direction.
- iii . Adjust white balance .
- iv . Carry out AUTO SHADING. Thus, color shading in the image is corrected automatically.

(14) DNR : Setting of noise reduction.

-MODE- : Selection of mode

- OFF : Not perform noise reduction.
ON (Factory setting) : Noise reduction function reduces the noise of image..

(15) VD/FVAL : Setting of vertical sync signal

- VD : Output VD.
FVAL (Factory setting) : Output FVAL.

(16) HD/LVAL : Setting of horizontal sync signal

- HD : Output HD.
LVAL (Factory setting) : Output LVAL.

(17) DATA BIT : Setting of output bit depth

- 24bit (Factory setting) : Configuration is set to Base configuration. Image is outputted by RGB 24 bit.
30bit : Configuration is set to Medium configuration. Image is outputted by RGB 30 bit.
36bit : Configuration is set to Medium configuration. Image is outputted by RGB 36 bit.

(18) OUTPUT SIGNAL : Setting of output signal from 10 pin of 12 pin DCIN connector

-MODE - : Selection of mode

- OFF (Factory setting) : No output.
FLASH OUT : Output flash pulse (strobe out).
VD : Output camera VD.

-POLARITY- : Selection of polarity

- POSITIVE (Factory setting) : Output High active signal.
NEGATIVE : Output Low active signal.

(19) WHITE SPOT : Setting of white spot correction

-MODE - : Selection of mode

- OFF (Factory setting) : Not perform white spot correction.
ON : Perform white spot correction.

-THRESHOLD R- : Threshold of white spot correction for Red CCD

- 0 to 255 : Set threshold value for Red CCD from 0 to 255.

-THRESHOLD G- : Threshold of white spot correction for Green CCD

- 0 to 255 : Set threshold value for Red CCD from 0 to 255.

-THRESHOLD B- : Threshold of white spot correction for Blue CCD

- 0 to 255 : Set threshold value for Red CCD from 0 to 255.

-DETECT- : Detect white spots

- : When this command is executed, the camera detects the pixel that level is higher than threshold and save it as white spot.

Note: Detectable number of white spot is up to 64 for each CCD.

(20) MEMORY CHANNEL : Setting of memory channel

-LOAD- : Load memory channel

DEFAULT (Factory setting): Return to the factory setting..

MEMORY 1 to MEMORY 4 : Load the memory channel 1 to 4

-SAVE- : Save memory channel

MEMORY 1 to MEMORY 4 : Save current settings to the memory channel 1 to 4

Remote control

1. Comms* specifications

- Control system : Start-stop synchronization system
- Transmission rate : 9600 bps
- Data length : 8 bit
- Star bit : 1 bit
- Stop bit : 1 bit
- Parity : None
- Bit transfer : LSB first

*Comms: Communications

2. Comms control

The remote control software controls all communications. Data send/receive (BSC handshake) is by transferring TEXT data to the camera controller chip.

3. Comms procedure

The following pages indicate the camera controller chip and remote control software data protocol. In the description, the camera is designated as slave and the software as master.

- Receive protect timer (time out error)

The receive protect timer for master and slave processes is 1 second. For example, if 1 block of TEXT data is being received, if the data interval exceeds 1 second, error is produced and the data are lost. An acknowledgment of data receipt is not produced.

(1) Transmission from master (normal process)

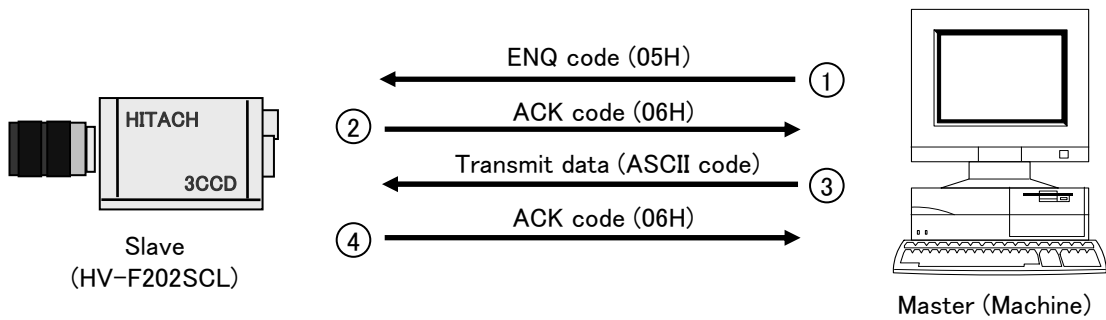

- ① Session starts when ENQ is sent from master to slave.
- ② Slave acknowledges by returning ACK to master.
- ③ Master sends data to slave.
- ④ Slave acknowledges receipt of data by again returning ACK to master and end the handshake.

(2) Master reads data (normal process)

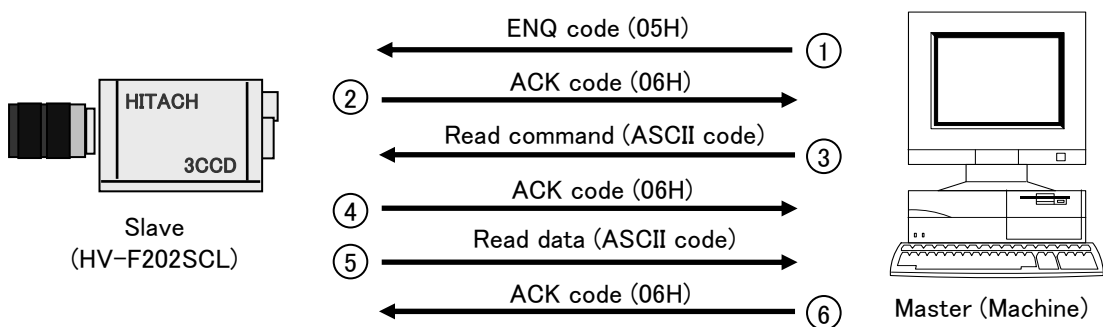

- ① Session starts when ENQ is sent from master to slave.
- ② Slave acknowledges by returning ACK to master.
- ③ Master sends read command to slave.
- ④ Slave receives read command, then acknowledges by returning ACK code to master.
- ⑤ Slave sends read data to master.
- ⑥ Master receives read data, then acknowledges by returning ACK code to slave.

(3) Data transmitted by master (control abort process)

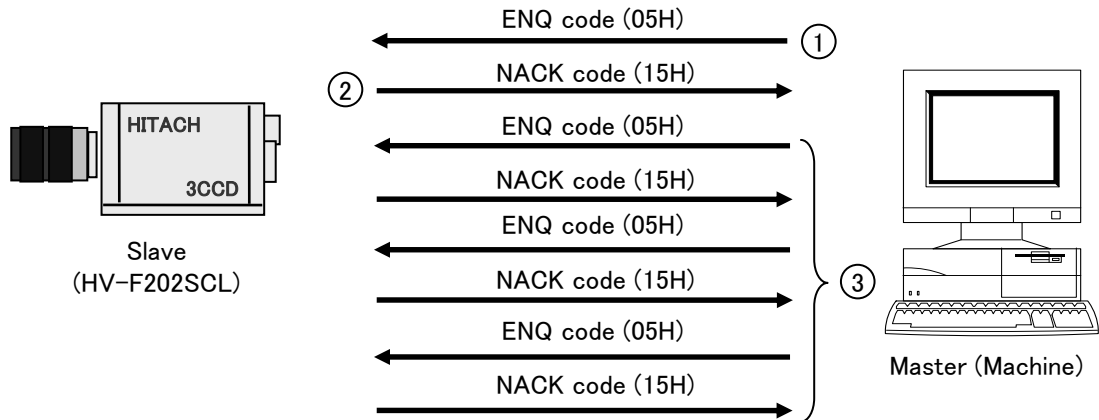

- ① Master sends ENQ code to slave.
 - ② Since ACK code cannot be sent, slave sent NACK code to master.
 - ③ Sequence is repeated 3 times in attempts to retransmit.
- After receiving the 3rd successive NACK code, communications control is aborted

(4) Data transmitted by master (data error process)

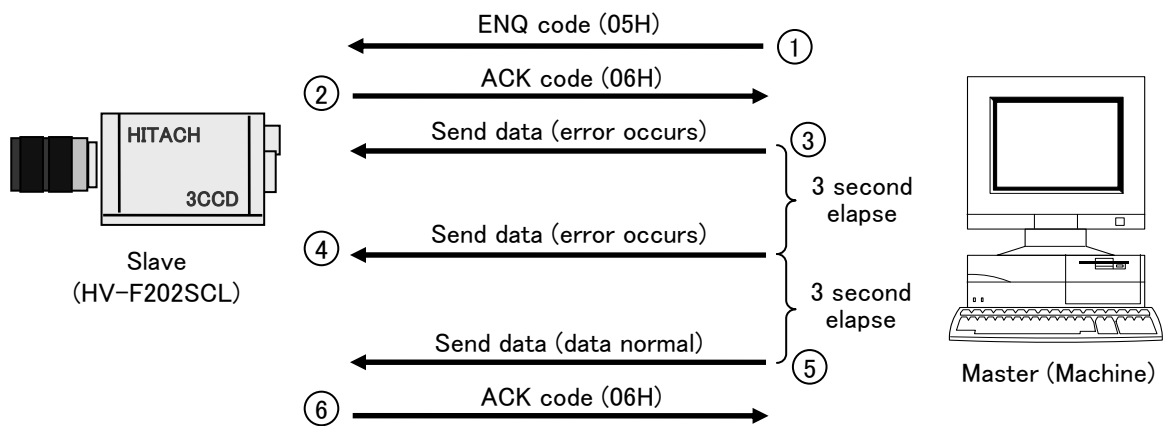

- ① Session starts when ENQ is sent from master to slave.
- ② Slave acknowledges by returning ACK to master.
- ③ Master sends data, but error detected (framing, over-run error).
- ④ Slave detects error and does not accept data.
- ⑤ Sequence 3 and 4 repeats, then master transfers normal data.
- ⑥ Slave detects normal data and returns ACK code to master to end the session.

(5) Data frame error (Master transmission)

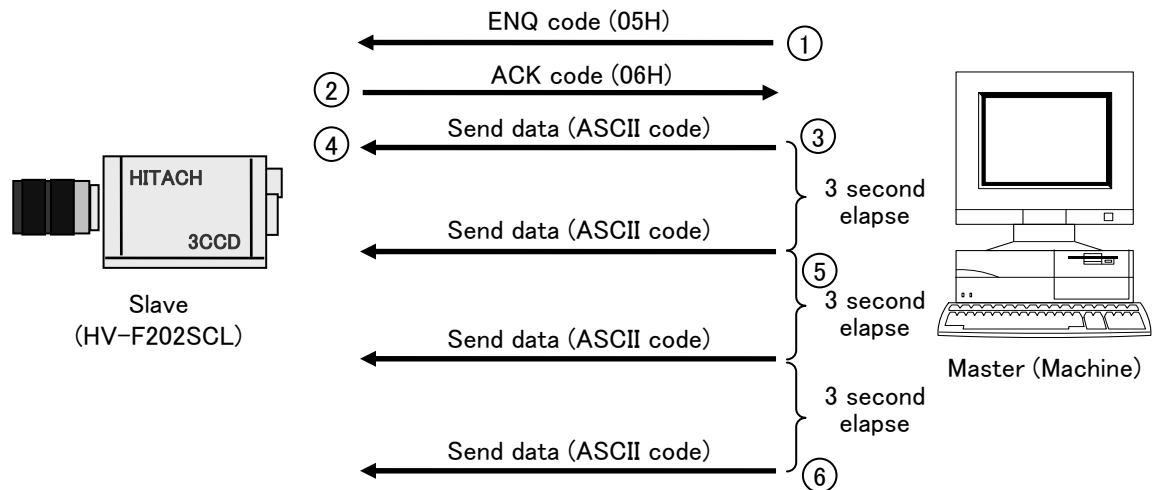

- ① Session starts when ENQ is sent from master to slave.
- ② Slave acknowledges by returning ACK to master.
- ③ Master sends data.
- ④ For some reason, slave does not receive data.
- ⑤ Master does not receive acknowledgment to the send data and repeats the sequence every 3 seconds for 3 times.
- ⑥ If unsuccessful after 3 attempts, master aborts the sequence and ends communication.

(6) Transmission frame error (Master receive)

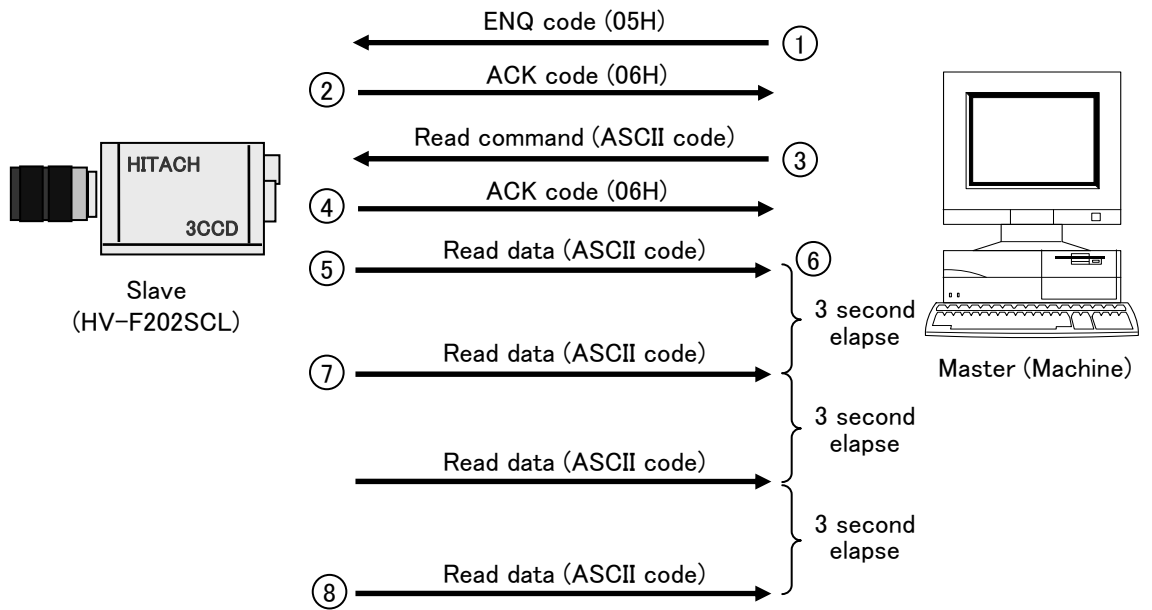

- ① Session starts when ENQ is sent from master to slave.
- ② Slave acknowledges by returning ACK to master.
- ③ Master sends read command.
- ④ Slave returns ACK code to acknowledge read command.
- ⑤ Slave sends read data to master.
- ⑥ For some reason, master fails to receive read data.
- ⑦ Slave fails to receive acknowledgment of read data and attempts to resend every 3 seconds for 3 times.
- ⑧ After the third failure, slave aborts the sequence and ends communication.

4. Comms command Text data format

(1) Send data and read command (master to slave)

(a) Command data are converted into ASCII code and transmitted.

(b) Comms byte quantity is 18.

(c) Comms data format (transmission sequence).



- STX (start code) : Code indicating start of text.
1 byte (02H)
- Text data : Transmit / receive data.
14 byte (ASCII code)
- ETX (end code) : Code indicating end of text.
1 byte (03H)
- SUM : XOR result (FFH), of adding STX, Text data, and ETX.
2 byte (ASCII code)

(d) Text data format details (transmission sequence).

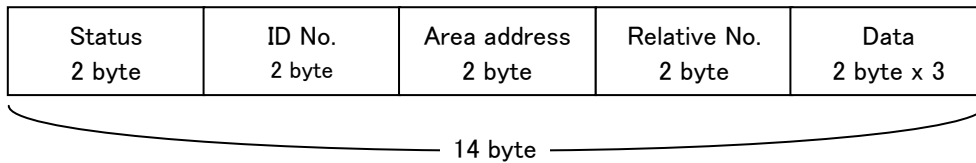

- Status : Transmission data status.
2 byte (ASCII code)
Used for EEPROM write (0: write absent, 1: write present).
- ID No. : Camera peculiar ID.
HV-F202SCL has (FFH).
2 byte (ASCII code)
- Area address : Classification of Send data (01H) and Read command (81H).
2 byte (ASCII code)
- Relative No. : Sets number (0 to 255) for each adjustment item.
2 byte (ASCII code)
- Data (note) : Sets data to be transmitted.
2 byte x 3 (ASCII code)

(2) Read (receive) data (slave to master)

- (a) Command data are converted into ASCII code and transmitted.
- (b) Comms byte quantity is 10.
- (c) Comms data format (transmission sequence)

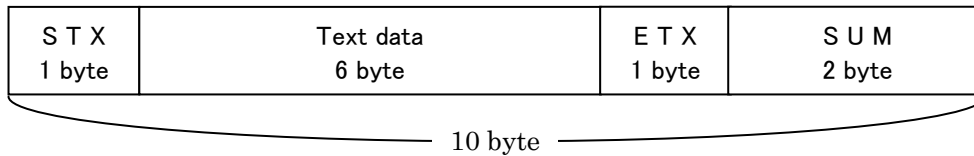

- STX (start code) : Code indicating start of text.
1 byte (02H)
- Text data : Transmit / receive data.
6 byte (ASCII code)
- ETX (end code) : Code indicating end of text.
1 byte (03H)
- SUM : XOR result (FFH), of adding STX, Text data, and ETX.
2 byte (ASCII code)

(d) Text data details (transmission sequence)

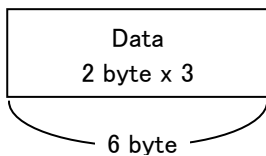

- Data (note) : Sets data to be transmitted.
2 byte x 3 (ASCII code)

Note: Data transfer sequence

Area address	Data type	Data bytes	1st byte	2nd byte	3rd byte
0x01 (Send data), 0x81 (Read command) (with some exceptions)	Common data	1	Data	0x00	0x00
		2	Upper	Lower	0x00
		3	Upper	Mid	Lower

5. Calculation method of checksum

Example

STX	1	2	3	4	5	6	7	ETX	SUM
	STATUS	ID NO	AREA ADDRESS	RELATIVE NO	DATA				
02	00	FF	01	04	00	00	00	03	29

i. STATUS to DATA are transformed into hexadecimal number on the basis of the ASCII code.

'0'→(30)₁₆ '1'→(31)₁₆ '4'→(34)₁₆ 'F'→(46)₁₆ STX: (02)₁₆ ETX: (03)₁₆

ii. STX to ETX are added all.

$$\underbrace{(02)_{16}}_{\text{STX}} + \underbrace{(30)_{16}}_{\text{STATUS}} + \underbrace{(30)_{16}}_{\text{ID}} + \underbrace{(46)_{16}}_{\text{AREA}} + \underbrace{(46)_{16}}_{\text{RELATIVE}} + \underbrace{(30)_{16}}_{\text{DATA}} + \underbrace{(31)_{16}}_{\text{DATA}} + \underbrace{(30)_{16}}_{\text{DATA}} + \underbrace{(34)_{16}}_{\text{DATA}} + \underbrace{(30)_{16}}_{\text{DATA}} + \underbrace{(30)_{16}}_{\text{DATA}} + \underbrace{(30)_{16}}_{\text{DATA}} + \underbrace{(30)_{16}}_{\text{DATA}} + \underbrace{(30)_{16}}_{\text{DATA}} + \underbrace{(03)_{16}}_{\text{ETX}} = (2D6)_{16}$$

iii. The XOR (Exclusive OR) between the value obtained in ii. clause and (FF)₁₆ are taken, then two column under the answer become SUM

(2D6)₁₆ XOR (FF)₁₆ = (229)₁₆

Command list

1. Send data (setting command, Note: 1 to 7 and SUM need to be transformed into ASCII code)

Item		STX	1	2	3	4	5	6	7	ETX	SUM	
			STATUS	ID NO.	AREA ADDRESS	RELATIVE NO.	DATA					
TRIGGER	MODE	OFF	02	00	FF	01	04	00	00	00	03	29
		FIXED	02	00	FF	01	04	01	00	00	03	28
		1TRIG	02	00	FF	01	04	02	00	00	03	27
		VD CONT	02	00	FF	01	04	04	00	00	03	25
	POLARITY	POSITIVE	02	00	FF	01	0F	00	00	00	03	17
		NEGATIVE	02	00	FF	01	0F	01	00	00	03	16
	SOURCE	CL-CC1	02	00	FF	01	05	00	00	00	03	28
12pin		02	00	FF	01	05	01	00	00	03	27	
SHUTTER SPEED (*1)	PRESET	OFF	02	00	FF	01	08	00	00	00	03	25
		1/30	02	00	FF	01	08	01	00	00	03	24
		1/60	02	00	FF	01	08	02	00	00	03	23
		1/100	02	00	FF	01	08	03	00	00	03	22
		1/250	02	00	FF	01	08	04	00	00	03	21
		1/1000	02	00	FF	01	08	05	00	00	03	20
		1/2000	02	00	FF	01	08	06	00	00	03	1F
		1/10000	02	00	FF	01	08	07	00	00	03	1E
		1/50000	02	00	FF	01	08	08	00	00	03	1D
		VARIABLE (*2)	02	00	FF	01	08	FF	00	00	03	F9
	VARIABLE VALUE (2Byte) (*3)	MIN (1/100000(s))	02	00	FF	01	11	00	00	00	03	2B
MAX (10(s))		02	00	FF	01	11	06	00	00	03	25	
GAIN(2Byte) (*4)		MIN (0)	02	00	FF	01	0C	00	00	00	03	1A
		MAX (341)	02	00	FF	01	0C	01	55	00	03	0F
BRIGHTNESS		MIN (0)	02	00	FF	01	17	00	00	00	03	25
		MAX (255)	02	00	FF	01	17	FF	00	00	03	F9
GAMMA	MODE	OFF	02	00	FF	01	23	00	00	00	03	28
		ON	02	00	FF	01	23	01	00	00	03	27
	LEVEL	MIN (0)	02	00	FF	01	24	00	00	00	03	27
		MAX (255)	02	00	FF	01	24	FF	00	00	03	FB
KNEE	MODE	ON	02	00	FF	01	42	00	00	00	03	27
		OFF	02	00	FF	01	42	01	00	00	03	26
	KNEE POINT	MIN (0)	02	00	FF	01	43	00	00	00	03	26
		MAX (32)	02	00	FF	01	43	20	00	00	03	24
	KNEE SLOPE	MIN (0)	02	00	FF	01	44	00	00	00	03	25
		MAX (159)	02	00	FF	01	44	9F	00	00	03	06
LUT	MODE	OFF	02	00	FF	01	25	00	00	00	03	26
		ON	02	00	FF	01	25	01	00	00	03	25
	TABLE R[n]	MIN (0)	02	00	FF	20	n (*5)	00	00	00	03	(*5)
		MAX (255)	02	00	FF	20	n (*5)	FF	00	00	03	(*5)
	TABLE G[n]	MIN (0)	02	00	FF	21	n (*5)	00	00	00	03	(*5)
		MAX (255)	02	00	FF	21	n (*5)	FF	00	00	03	(*5)
	TABLE B[n]	MIN (0)	02	00	FF	22	n (*5)	00	00	00	03	(*5)
		MAX (255)	02	00	FF	22	n (*5)	FF	00	00	03	(*5)
SHARPNESS	MODE	OFF	02	00	FF	01	27	00	00	00	03	24
		ON	02	00	FF	01	27	01	00	00	03	23
	LEVEL	MIN (0)	02	00	FF	01	28	00	00	00	03	23
		MAX (255)	02	00	FF	01	28	FF	00	00	03	F7
ALC	MODE	OFF	02	00	FF	01	0B	00	00	00	03	1B
		AGC	02	00	FF	01	0B	01	00	00	03	1A
		AES	02	00	FF	01	0B	02	00	00	03	19
		AGC & AES	02	00	FF	01	0B	03	00	00	03	18
	VIDEO LEVEL	MIN (0)	02	00	FF	01	26	00	00	00	03	25
		MAX (255)	02	00	FF	01	26	FF	00	00	03	F9

(*1) SHUTTER SPEED settings are not effective when ONE TRIGGER mode or AES is ON.

(*2) VARIABLE VALUE can be set only when VARIABLE is selected.

(*3) VARIABLE VALUE; Selectable in the range from 0000₁₆ to 0600₁₆ (see page 5 to 6 about shutter speed setting).

(*4) Setting of GAIN LEVEL when AGC is OFF.

(*5) RELATIVE NO of TABLE R/G/B is table number from 0 to 255 (00₁₆ to FF₁₆), and SUM follows it.

Item		STX	1	2	3	4	5	6	7	ETX	SUM		
			STATUS	ID NO.	AREA ADDRESS	RELATIVE NO.	DATA						
WHITE BALANCE	MODE	ATW	02	00	FF	01	29	00	00	00	03	22	
		MANUAL	02	00	FF	01	29	02	00	00	03	20	
		AWC ADJUST (*1)	02	00	FF	01	29	03	00	00	03	1F	
	R-GAIN	MIN (0)	02	00	FF	01	2A	00	00	00	03	1A	
		MAX (255)	02	00	FF	01	2A	FF	00	00	03	EE	
	B-GAIN	MIN (0)	02	00	FF	01	2B	00	00	00	03	19	
MAX (255)		02	00	FF	01	2B	FF	00	00	03	ED		
MASKING	MODE	OFF	02	00	FF	01	31	00	00	00	03	29	
		ON	02	00	FF	01	31	01	00	00	03	28	
	R-SATURATION	MIN (0)	02	00	FF	01	32	00	00	00	03	28	
		MAX (255)	02	00	FF	01	32	FF	00	00	03	FC	
	R-HUE	MIN (0)	02	00	FF	01	33	00	00	00	03	27	
		MAX (255)	02	00	FF	01	33	FF	00	00	03	FB	
	Cy-SATURATION	MIN (0)	02	00	FF	01	34	00	00	00	03	26	
		MAX (255)	02	00	FF	01	34	FF	00	00	03	FA	
	Cy-HUE	MIN (0)	02	00	FF	01	35	00	00	00	03	25	
		MAX (255)	02	00	FF	01	35	FF	00	00	03	F9	
	G-SATURATION	MIN (0)	02	00	FF	01	36	00	00	00	03	24	
		MAX (255)	02	00	FF	01	36	FF	00	00	03	F8	
	G-HUE	MIN (0)	02	00	FF	01	37	00	00	00	03	23	
		MAX (255)	02	00	FF	01	37	FF	00	00	03	F7	
	Mg-SATURATION	MIN (0)	02	00	FF	01	38	00	00	00	03	22	
		MAX (255)	02	00	FF	01	38	FF	00	00	03	F6	
	Mg-HUE	MIN (0)	02	00	FF	01	39	00	00	00	03	21	
		MAX (255)	02	00	FF	01	39	FF	00	00	03	F5	
	B-SATURATION	MIN (0)	02	00	FF	01	3A	00	00	00	03	19	
		MAX (255)	02	00	FF	01	3A	FF	00	00	03	ED	
	B-HUE	MIN (0)	02	00	FF	01	3B	00	00	00	03	18	
		MAX (255)	02	00	FF	01	3B	FF	00	00	03	EC	
	Ye-SATURATION	MIN (0)	02	00	FF	01	3C	00	00	00	03	17	
		MAX (255)	02	00	FF	01	3C	FF	00	00	03	EB	
	Ye-HUE	MIN (0)	02	00	FF	01	3D	00	00	00	03	16	
		MAX (255)	02	00	FF	01	3D	FF	00	00	03	EA	
	PAINT BLACK	MODE	OFF	02	00	FF	01	3E	00	00	00	03	15
			ON	02	00	FF	01	3E	01	00	00	03	14
RED		MIN (0)	02	00	FF	01	3F	00	00	00	03	14	
		MAX (255)	02	00	FF	01	3F	FF	00	00	03	E8	
GREEN		MIN (0)	02	00	FF	01	40	00	00	00	03	29	
		MAX (255)	02	00	FF	01	40	FF	00	00	03	FD	
BLUE		MIN (0)	02	00	FF	01	41	00	00	00	03	28	
		MAX (255)	02	00	FF	01	41	FF	00	00	03	FC	
WHITE SHADING	MODE	OFF	02	00	FF	01	52	00	00	00	03	26	
		ON	02	00	FF	01	52	01	00	00	03	25	
	ADJUST	02	00	FF	01	53	01	00	00	03	24		
DNR	MODE	OFF	02	00	FF	01	57	00	00	00	03	21	
		ON	02	00	FF	01	57	01	00	00	03	20	

(*1) AWC ADJUST can be used only when MODE is MANUAL.

Item		STX	1	2	3	4	5	6	7	ETX	SUM	
			STATUS	ID NO.	AREA ADDRESS	RELATIVE NO.	DATA					
VD/FVAL	VD	02	00	FF	01	15	00	00	00	03	27	
	FVAL	02	00	FF	01	15	01	00	00	03	26	
HD/LVAL	HD	02	00	FF	01	16	00	00	00	03	26	
	LVAL	02	00	FF	01	16	01	00	00	03	25	
DATA BIT	24bit	02	00	FF	01	14	00	00	00	03	28	
	30bit	02	00	FF	01	14	01	00	00	03	27	
	36bit	02	00	FF	01	14	02	00	00	03	26	
OUTPUT	SIGNAL	OFF	02	00	FF	01	06	00	00	00	03	27
		FLASH OUT	02	00	FF	01	06	01	00	00	03	26
		VD	02	00	FF	01	06	02	00	00	03	25
	POLARITY	POSITIVE	02	00	FF	01	55	00	00	00	03	23
		NEGATIVE	02	00	FF	01	55	01	00	00	03	22
WHITE SPOT	MODE	OFF	02	00	FF	01	4B	00	00	00	03	17
		ON	02	00	FF	01	4B	01	00	00	03	16
	THRESHOLD	MIN (0)	02	00	FF	01	4C	00	00	00	03	16
		MAX (255)	02	00	FF	01	4C	FF	00	00	03	EA
	DETECT	02	00	FF	01	4D	01	00	00	03	14	
MEMORY	LOAD	MIN (DEFAULT)	02	00	FF	01	02	00	00	00	03	2B
		CH 1	02	00	FF	01	02	01	00	00	03	2A
		MAX (CH 4)	02	00	FF	01	02	04	00	00	03	27
	SAVE	MIN (CH 1)	02	00	FF	01	03	01	00	00	03	29
		MAX (CH 4)	02	00	FF	01	03	04	00	00	03	26

2. Read-out command (Note: 1 to 7 and SUM need to be transformed into ASCII code)

Item		STX	1	2	3	4	5	6	7	ETX	SUM
			STATUS	ID NO.	AREA ADDRESS	RELATIVE NO.	DATA				
TRIGGER	MODE	02	00	FF	81	04	00	00	00	03	21
	SOURCE	02	00	FF	81	05	00	00	00	03	20
	POLARITY	02	00	FF	81	0F	00	00	00	03	F
SHUTTER SPEED	PRESET	02	00	FF	81	08	00	00	00	03	1D
	VARIABLE VALUE	02	00	FF	81	11	00	00	00	03	23
GAIN LEVEL		02	00	FF	81	0C	00	00	00	03	12
BRIGHTNESS		02	00	FF	81	17	00	00	00	03	1D
GAMMA	MODE	02	00	FF	81	23	00	00	00	03	20
	LEVEL	02	00	FF	81	24	00	00	00	03	1F
KNEE	MODE	02	00	FF	81	42	00	00	00	03	1F
	POINT	02	00	FF	81	43	00	00	00	03	1E
	SLOPE	02	00	FF	81	44	00	00	00	03	1D
LUT	MODE	02	00	FF	81	25	00	00	00	03	1E
	TABLE R[n]	02	00	FF	A0	n(*1)	00	00	00	03	(*1)
	TABLE G[n]	02	00	FF	A1	n(*1)	00	00	00	03	(*1)
	TABLE B[n]	02	00	FF	A2	n(*1)	00	00	00	03	(*1)
SHARPNESS	MODE	02	00	FF	81	27	00	00	00	03	1C
	LEVEL	02	00	FF	81	28	00	00	00	03	1B
ALC	MODE	02	00	FF	81	0B	00	00	00	03	13
	VIDEOLEVEL	02	00	FF	81	26	00	00	00	03	1D
WHITE BALANCE	MODE	02	00	FF	81	29	00	00	00	03	1A
	R-GAIN	02	00	FF	81	2A	00	00	00	03	12
	B-GAIN	02	00	FF	81	2B	00	00	00	03	11
MASKING	MODE	02	00	FF	81	31	00	00	00	03	21
	R-SATURATION	02	00	FF	81	32	00	00	00	03	20
	R-HUE	02	00	FF	81	33	00	00	00	03	1F
	Cy-SATURATION	02	00	FF	81	34	00	00	00	03	1E
	Cy-HUE	02	00	FF	81	35	00	00	00	03	1D
	G-SATURATION	02	00	FF	81	36	00	00	00	03	1C
	G-HUE	02	00	FF	81	37	00	00	00	03	1B
	Mg-SATURATION	02	00	FF	81	38	00	00	00	03	1A
	Mg-HUE	02	00	FF	81	39	00	00	00	03	19
	B-SATURATION	02	00	FF	81	3A	00	00	00	03	11
	B-HUE	02	00	FF	81	3B	00	00	00	03	10
	Ye-SATURATION	02	00	FF	81	3C	00	00	00	03	0F
Ye-HUE	02	00	FF	81	3D	00	00	00	03	0E	
PAINT BLACK	MODE	02	00	FF	81	3E	00	00	00	03	0D
	RED	02	00	FF	81	3F	00	00	00	03	0C
	GREEN	02	00	FF	81	40	00	00	00	03	21
	BLUE	02	00	FF	81	41	00	00	00	03	20
WHITE SHADING	MODE	02	00	FF	81	52	00	00	00	03	1E
DNR	MODE	02	00	FF	81	57	00	00	00	03	19
VD / FVAL		02	00	FF	81	15	00	00	00	03	1F
HD / LVAL		02	00	FF	81	16	00	00	00	03	1E
DATA BIT		02	00	FF	81	14	00	00	00	03	20
OUTPUT	SIGNAL	02	00	FF	81	06	00	00	00	03	1F
	POLARITY	02	00	FF	81	55	00	00	00	03	1B
WHITE SPOT	MODE	02	00	FF	B0	4B	00	00	00	03	6
	THRESHOLD R	02	00	FF	B0	4C	00	00	00	03	5
MEMORY	LOAD CH	02	00	FF	81	02	00	00	00	03	23

(*1) RELATIVE NO of TABLE R/G/B is table number from 0 to 255 (00₁₆ to FF₁₆), and SUM follows it.

Read data from Slave is based on "4. Comms command data format(2)" of "Remote control" (page 15).

CameraLink output timing chart

1. Horizontal timing

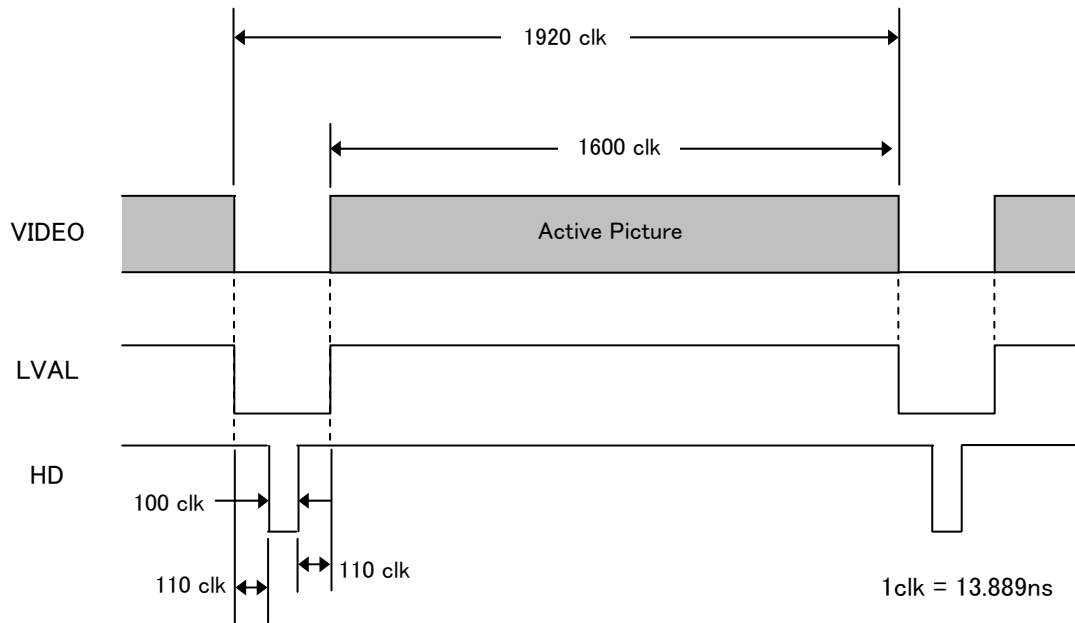

2. Vertical timing

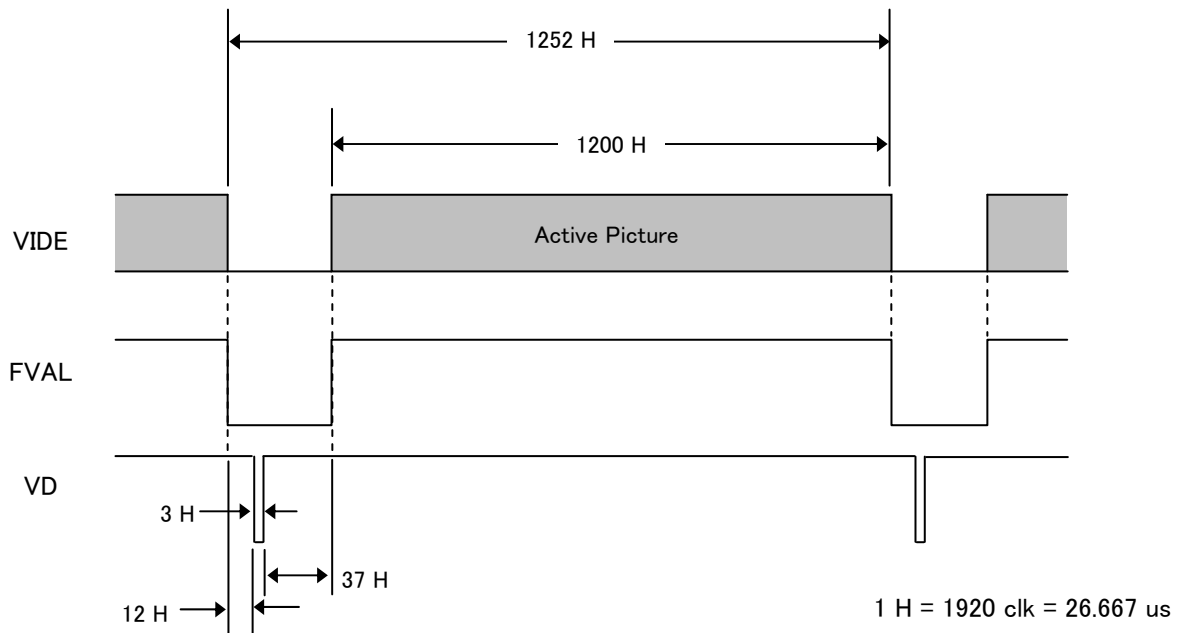

3. Transmitter LVDS output pulse position measurement

(1) Base Configuration

(a) 24bit

D.OUT 1

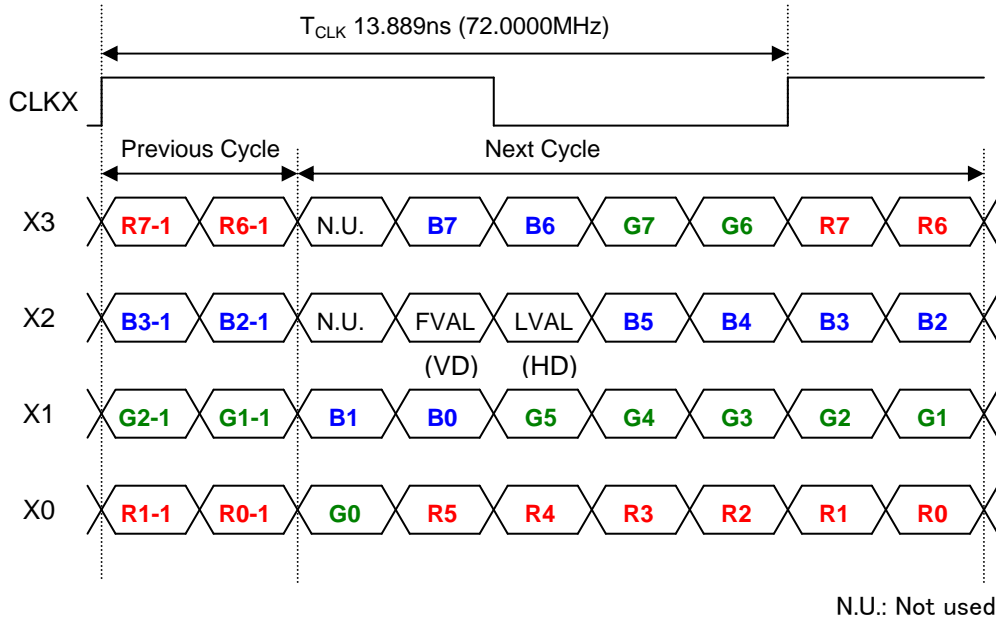

When using at Base configuration, please be sure to connect CameraLink cable to D.OUT 1. If the cable is connected to D.OUT 2, machine may break down.

(2) Medium Configuration

(a) 30bit
D.OUT 1

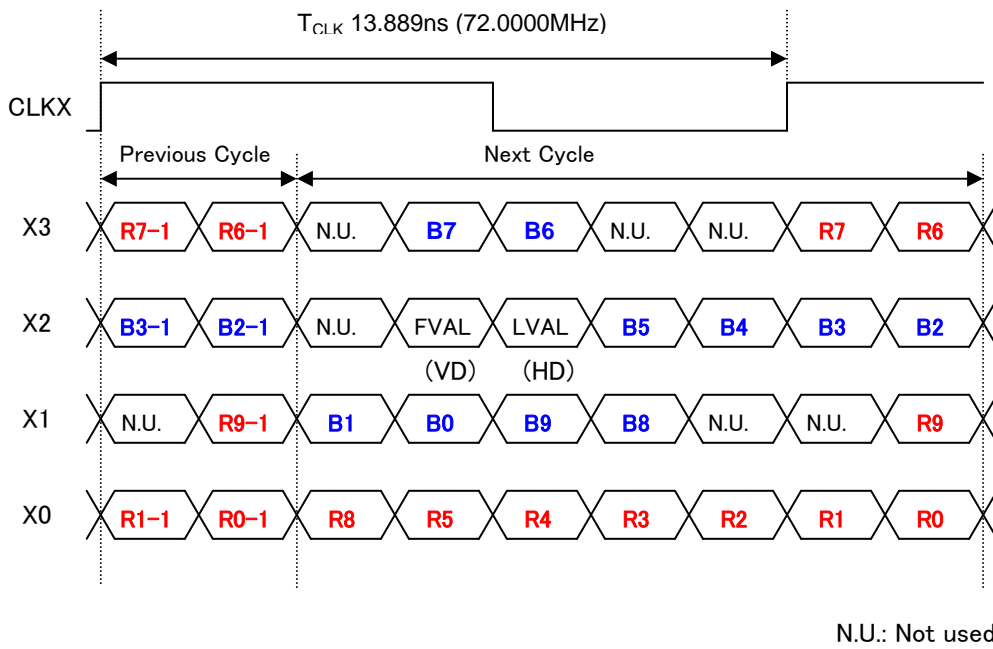

D.OUT 2

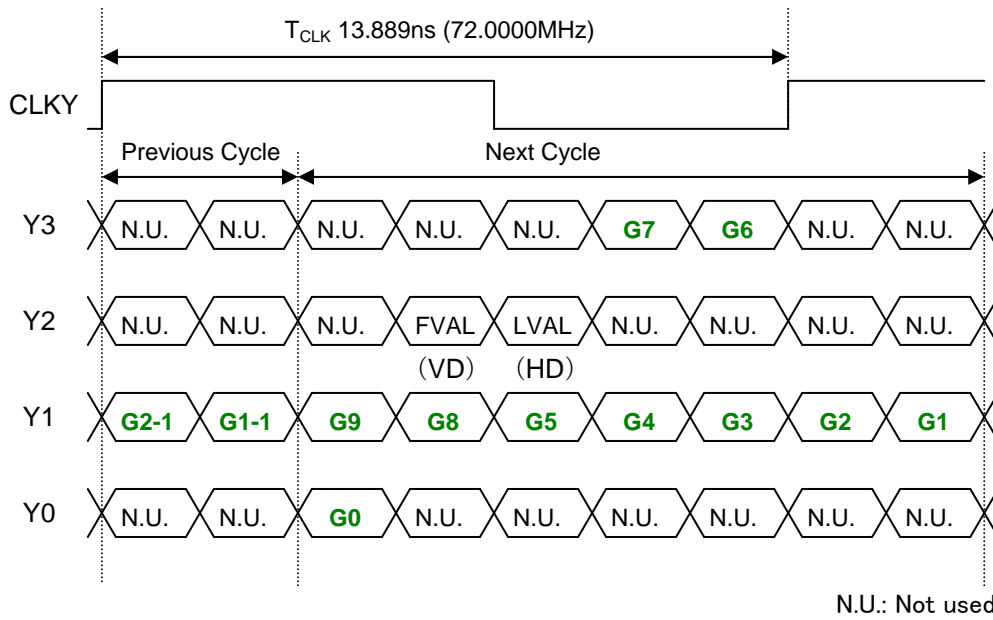

(b) 36bit
D.OUT 1

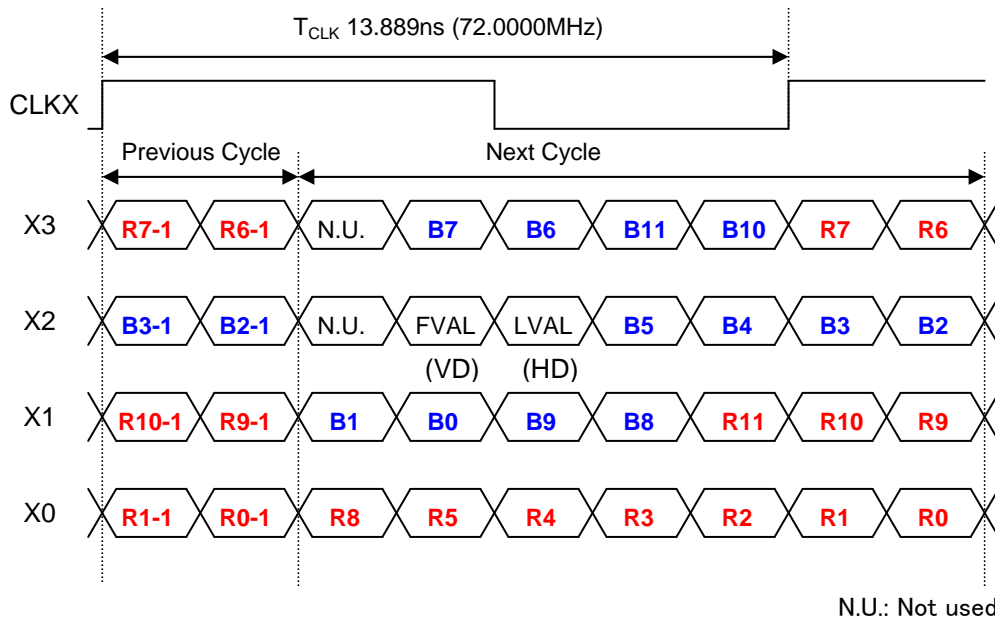

D.OUT 2

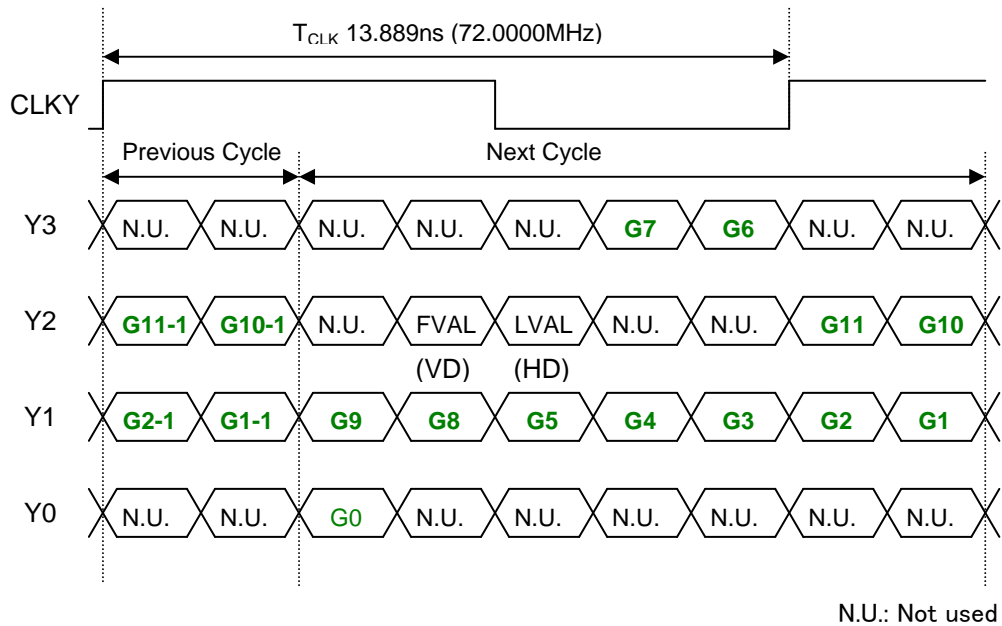

Trigger operation and timing chart

1. Normal mode

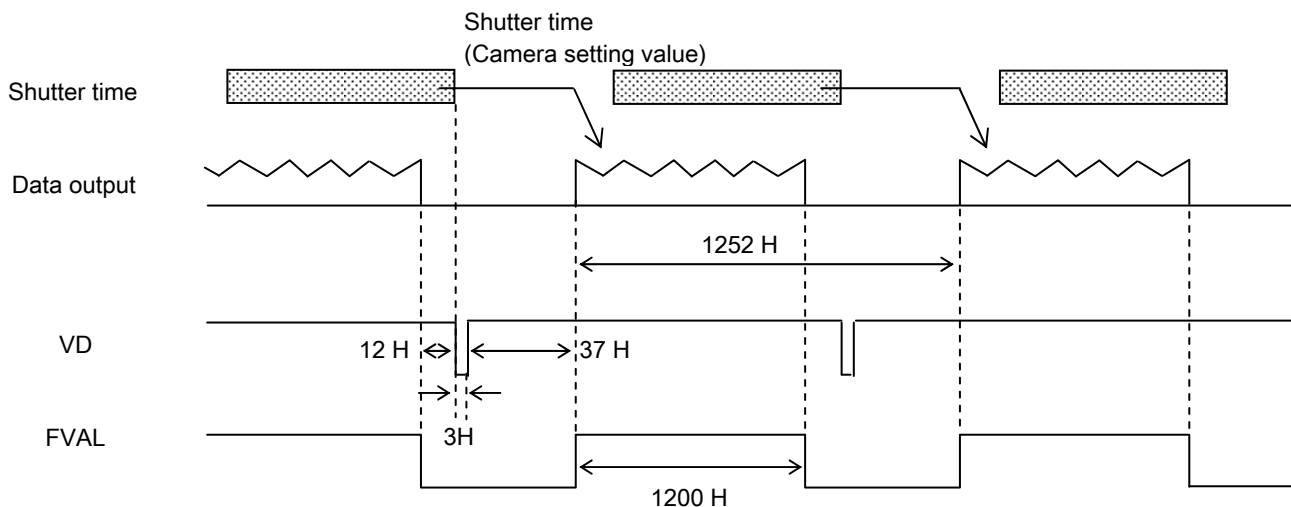

2. Fixed shutter mode

When external trigger signal is POSITIVE (high active), after the trigger signal rise, exposure is start. The exposure time is set by the camera electronic shutter speed. The video output is obtained immediately after the end of fixed exposure. The strobe signal start/end can be set to shutter time.

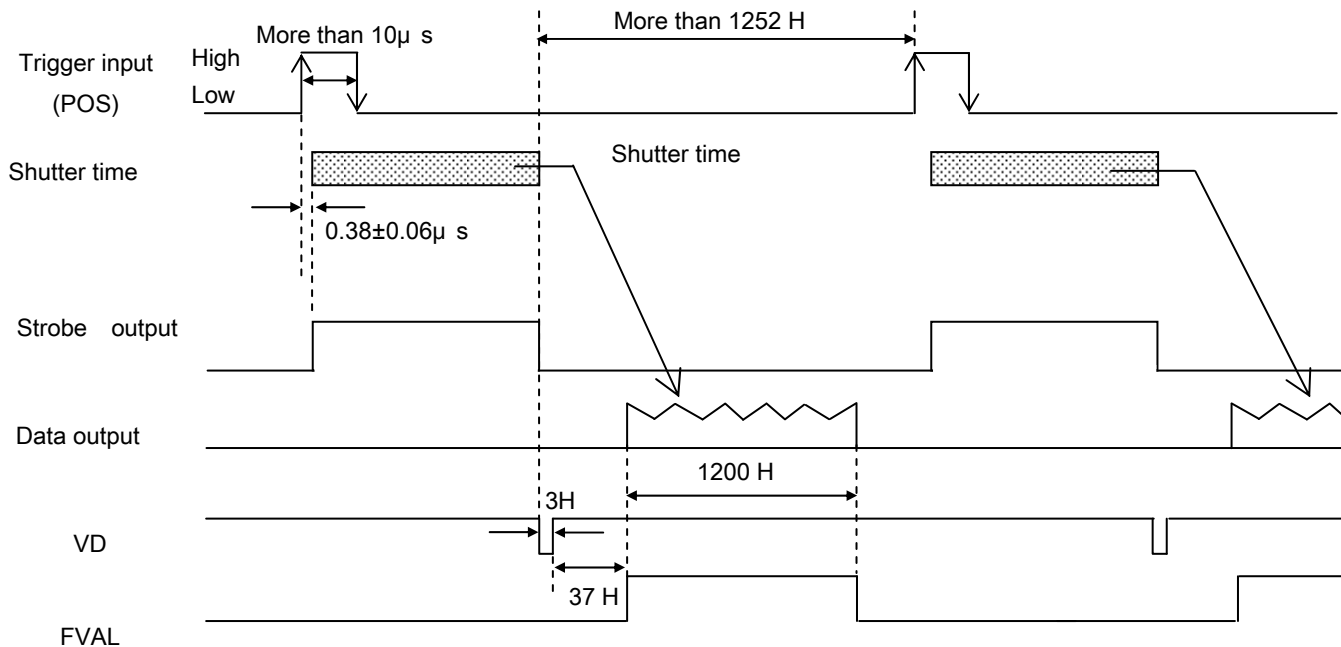

3. ONE trigger mode

When external trigger signal is POSITIVE (high active), after the trigger signal rise, exposure is start. At the trigger signal falling edge, the internal VD signal is reset and the video data are transmitted. The trigger signal width equals the exposure time.

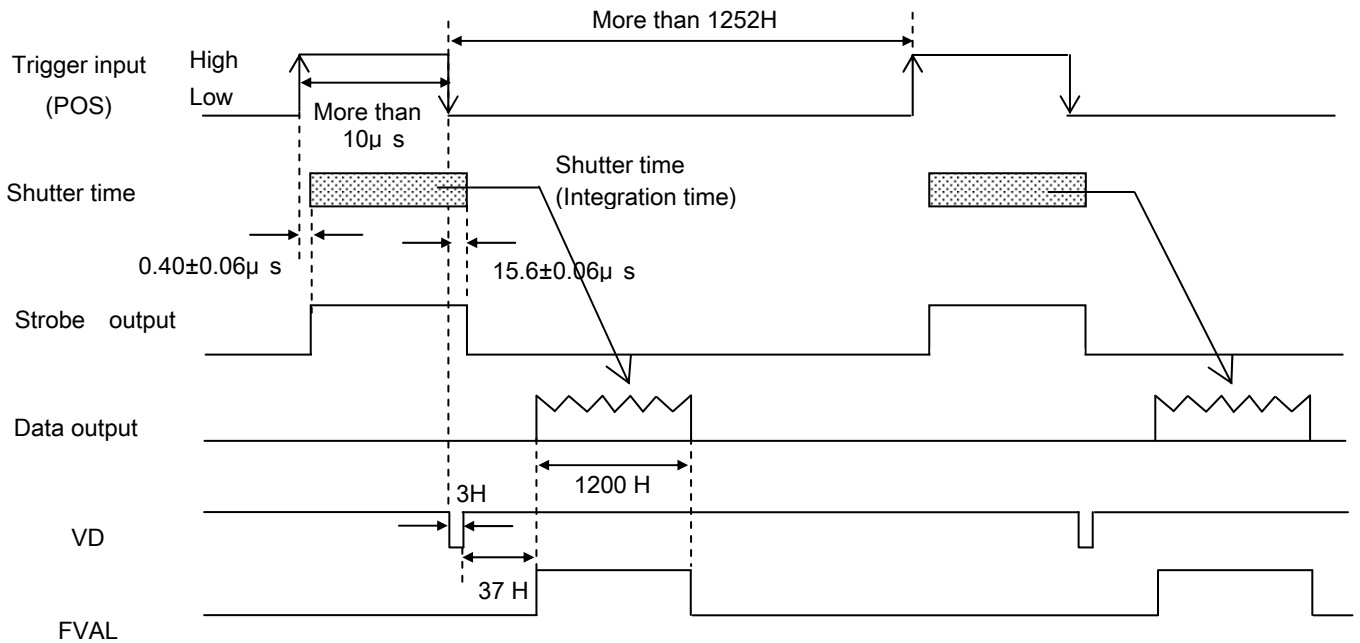

4. VD reset

When external VD pulse is inputted, internal VD is reset. Exposure time is established shutter speed.

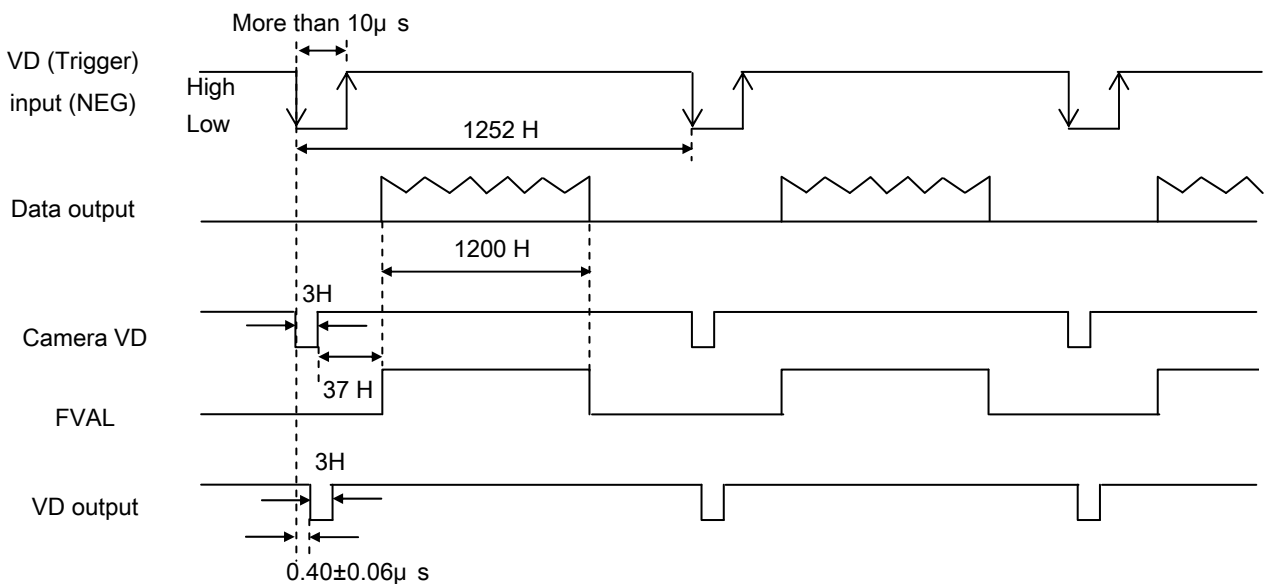

NOTE: If the external VD of cycle which does not match the camera operation mode is input, shutter time has an error.

Input / Output signal

1. Input signal

The level of the trigger signal input to HV-F202SCL is as follows.

- (1) Input from CameraLink cable
LVDS level.
- (2) Input from 12-pin connector
5Vp-p \pm 0.5V

2. Output signal

The level of the trigger signal output from HV-F202SCL is as follows.

5Vp-p

Spectral response

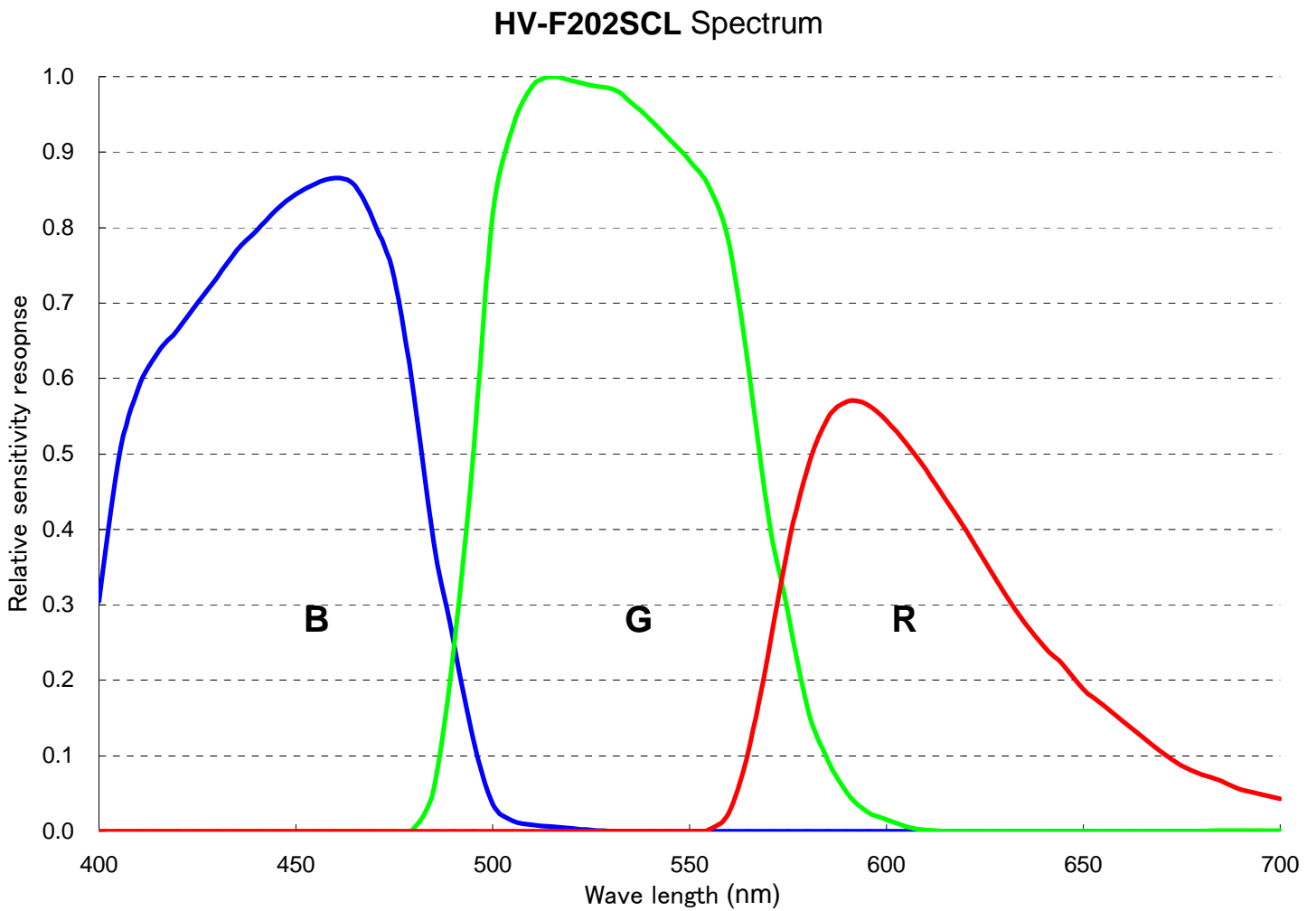

Specifications

Specifications of HV-F202SCL are showing.

1)	Optical system	1/1.8-inch F1.8 prism with IR cut filter
2)	Imaging device	1/1.8-inch interline CCD
	Total pixels	1688 (H) x 1248 (V)
	Effective pixels	1628 (H) x 1236 (V)
	Active pixels	1600 (H) x 1200 (V)
	Pixel pitch	4.4 μ m (H) x 4.4 μ m (V)
3)	Sensing area	7.13mm (H) x 5.37mm (V)
4)	Scanning system	Progressive scan
5)	Frame rate	30 frames per second
6)	Horizontal drive frequency	72.0000 MHz
7)	Horizontal scanning frequency	37.5 kHz
8)	Vertical scanning frequency	29.95 Hz
9)	Synchronization	Internal / VD external
10)	Lens mount	C mount (Mount surface projection less than 4.0mm)
11)	Frang back	17.526mm (air conversion)
12)	Video output	
	Interface	CameraLink 72.0000 MHz Base / Medium configuration (Note: Maximum digital out cable length is 10 meters.)
	Output image size	1600 (H) x 1200 (V)
	Output system	Base Configuration RGB24bit, Medium Configuration RGB30bit/RGB36bit
13)	Sensitivity	2000lx, F5.6, 3200K
14)	Minimum illumination	10lx (F1.4, Gain MAX)
15)	Electronic shutter	
	Preset	1/30, 1/60, 1/100, 1/250, 1/1000, 1/2000, 1/10000 and 1/50000 second
	Auto	1/29.95 to 1/100000 second
	Variable	10 to 1/100000 second
16)	Frame on demand	
	Mode	OFF (Normal mode), Fixed shutter mode, ONE trigger mode, VD reset mode
	Trigger input	From CameraLink (CC1) or DCIN/SYNC 12pin connector
	Input level	5Vp-p \pm 0.5V
17)	Output signal	Strobe / VD : 5Vp-p
18)	Gamma	0.45 / 1.0 / LUT
19)	Gain	Manual / AGC : 0 to +12dB
20)	White balance	Manual / One-push Auto/ Continuous Auto
21)	Registration	Full screen 0.05% (not including lens response)
22)	Vertical contour correction	2H
23)	Remote control	
	Control system	Start-stop synchronization system
	Control items	TRIGGER, SHUTTER SPEED, GAIN LEVEL, BRIGHTNESS, GAMMA, KNEE, LUT, SHARPNESS, ALC, WHITE BALANCE, MASKING, PAINT BLACK, WHITE SHADING VD/FVAL, HD/LVAL, DATA BIT, OUTPUT SIGNAL, WHITE SPOT, MEMORY
24)	Power supply	DC12V \pm 1V
25)	Power consumption	Approx 600mA (Approx 7.2W)
26)	Ambient temperature	
	Operating	0 to 40°C less than 90% RH (without dew condensation)
	Storage	-10 to 50°C less than 70% RH (without dew condensation)
27)	Vibration endurance	10 to 100Hz (24.5 m/s ²), sweep: 10 minutes, XYZ, 30minutes
28)	Shock endurance	392 m/s ² (vertical, horizontal, once each faze)
29)	Dimensions	55(W) x 55(H) x 89(D) mm (not including mount protrusions)
30)	Mass	Approx. 350g (not including the lens)
31)	Standard compositions	Camera, Installation guide, Plug for power supply

Dimensions

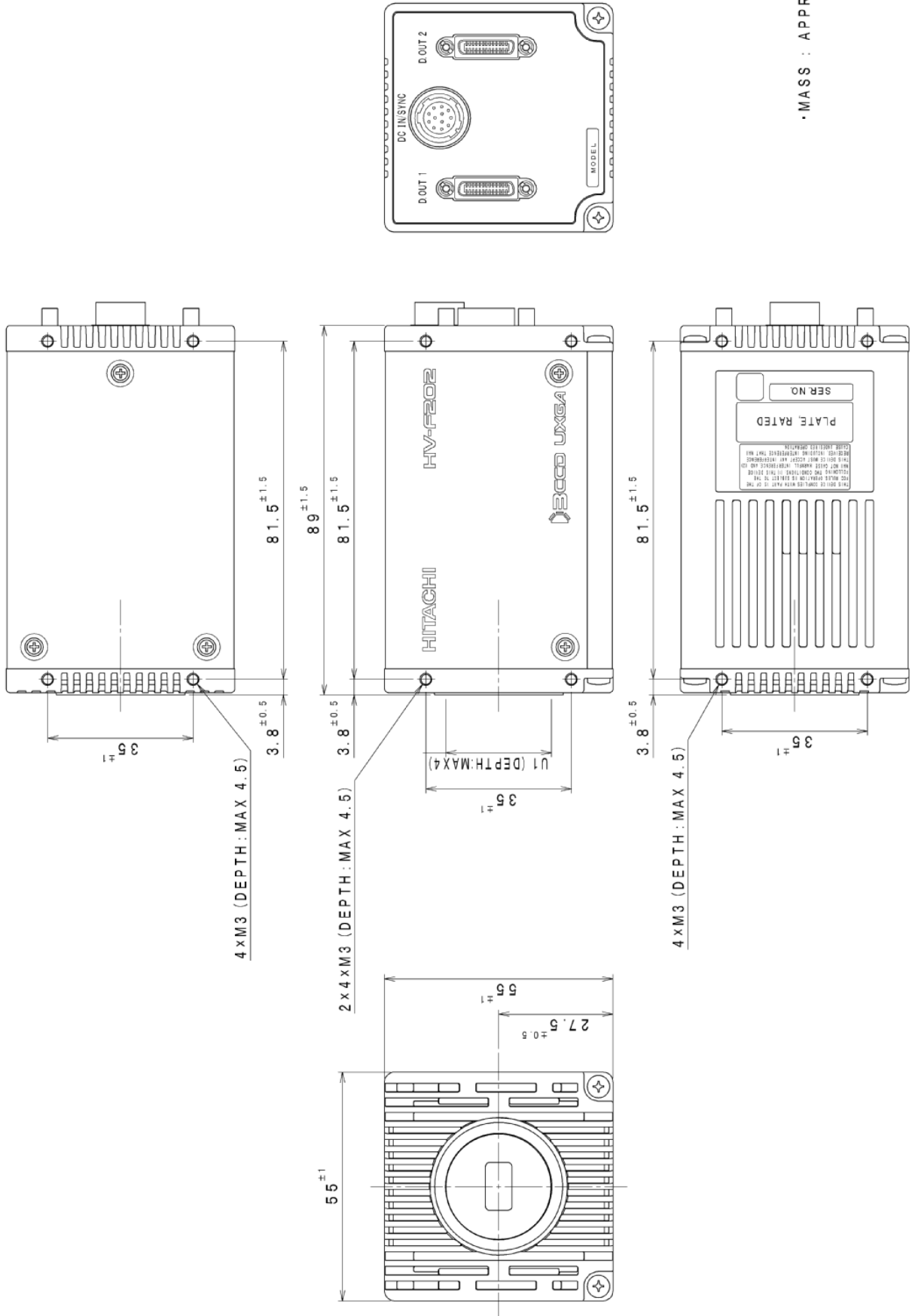

•MASS : APPROX. 350 g

Hitachi Kokusai Electric Inc.

UDX Akihabara Bldg.

14-1 Sotokanda 4-choume, Chiyoda-ku, Tokyo 101-8980, Japan

Phone: +81(0)3-6734-9432, Fax: +81(0)3-5209-5942

URL: <http://www.hitachi-kokusai.co.jp/global/>

Hitachi Kokusai Electric (Shanghai) Co., Ltd.

Beijing Branch : Room 1415, Beijing Fortune Building, 5 Dong San Huan Bei-Lu,
Chao Yang District, Beijing, 100004 China

Phone: +86(0) 10-6590-8755/8756, Fax: +86(0) 10-6590-8757

Hitachi Kokusai Electric America, Ltd.

Headquarters and Northeast Office : 150 Crossways Park Drive, Woodbury, New York 11797, U.S.A.

Phone: (+1) 516-921-7200,

Fax: (+1) 516-496-3718

Midwest Sales : Phone: (+1) 330-334-4115, Service: (+1) 989-345-5379,

Fax: (+1) 516-496-3718

South Sales : Phone: (+1) 850-934-1234, Service: (+1) 256-774-3777

Latin Sales : Phone: (+1) 519-682-4420,

Fax: (+1) 516-496-3718

Parts Center : Phone: (+1) 516-682-4435,

Fax: (+1) 516-921-0993

West Office : 11258 Monarch, Unite Garden Grove, CA 92841, U.S.A.

Phone: (+1) 310-328-6116,

Fax: (+1) 310-328-6252

URL: <http://www.hitachikokusai.us>

Hitachi Kokusai Electric Canada, Ltd.

Head Office : 1 Select Avenue, Unit#11, Scarborough, Ontario M1V, 5J3, Canada

Phone: (+1) 416-299-5900, Fax: (+1) 416-299-0450

Eastern Office : 5795 Chemin St. Francois St. Laurent, Quebec H4S, 1B6, Canada

Phone: (+1) 514-332-6687, Fax: (+1) 514-335-1664

URL: <http://www.hitachikokusai.ca>

Hitachi Kokusai Electric Europe GmbH

Sales and Engineering Frankfurt Office : Siemensstr. 9, D-63263 Neu-Isenburg, Germany

Phone: +49(0) 6102-8332-0, Fax: +49(0) 6102-202616

London Office : Windsor House, Britannia Road, Waltham Cross,

Hertfordshire EN8 7NX, United Kingdom

Phone: +44(0) 845-121-2177, Fax: +44(0) 845-121-2180

General email address: webmaster@hitachi-keu.com

URL: <http://www.hitachi-keu.com/>