

SONY®

Color Video Cameras

BRC Series



BRC-H700
BRC-Z700
BRC-300
BRC-300P

The High-performance BRC Series – Outstanding Picture Quality, Precise Movements, and Versatile Interfaces Make These Cameras Ideal for Remote Video Shooting Applications

The Sony BRC Series consists of three revolutionary Pan/Tilt/Zoom (PTZ) color video cameras, each especially designed for remote video shooting applications. Both the BRC-H700 and BRC-300 have already been highly successful worldwide, satisfying user needs for high-definition (HD) and standard-definition (SD) applications, respectively.

Now, Sony introduces the new BRC-Z700, equipped with three 1/4-type HD ClearVid CMOS Sensors™. This camera is both HD and SD capable, enabling versatile operations and allowing users to easily migrate from SD to HD picture quality. What's more, the BRC-Z700 incorporates a newly designed smooth PTZ mechanism for precise camera control.

The BRC Series has very wide pan and tilt ranges, as well as extremely fast and accurate pan/tilt movements, making it suitable for capturing not only fast-moving objects, but also slow-moving objects without rocking vibration. Moreover, users can operate the camera intuitively with the optional Sony RM-BR300 Remote Control Unit, which is equipped with an ergonomically designed joystick and feature-rich control panel. With the RM-BR300, users can control up to seven cameras, the presets for each camera, and other parameters as required. In addition, the BRC Series can be controlled over long distances via a single fiber optic cable connection.

With a number of useful features and excellent picture quality, the BRC Series is ideal for a variety of remote video shooting applications, such as in houses of worship, auditoriums, teaching hospitals, corporate boardrooms, and at sporting events, trade shows, and concerts. Furthermore, it is an excellent choice for broadcast applications, such as the recording of television programs or as a weather camera. The BRC Series consists of three cameras each with specific benefits, so users can choose the most appropriate solution for their specific application needs.

BRC-H700 (HD 3CCD Color Video Camera)

The BRC-H700 offers high picture quality and high sensitivity with three 1/3-type HD CCDs and a resolution of 1,120,000 total pixels. It is ideal for users demanding extremely clear HD images with great detail, and because of its high sensitivity, it can be operated in shooting environments without ideal lighting. Furthermore, it has the widest viewing angle in the BRC Series, allowing users to capture wide areas of a scene such as audiences at concerts or in auditoriums.



BRC-Z700 (HD/SD 3CMOS Color Video Camera)

The BRC-Z700 incorporates three 1/4-type HD ClearVid CMOS Sensors and achieves a resolution of 1,120,000 total pixels. It features a 20x optical auto-focus zoom lens with an optical image stabilizer, allowing users to clearly capture small or distant objects. The BRC-Z700 also offers dual HD/SD outputs and an enhanced Pan/Tilt mechanism that operates with extremely smooth and precise movements.

BRC-300 (SD 3CCD Color Video Camera)

The standard-definition BRC-300 incorporates three 1/4.7-type Advanced HAD™ CCD sensors with a total of 1,070,000 pixels. It is an ideal camera for cost-effective SD applications – and it can capture images in both 4:3 and 16:9 aspect ratios, the latter offering a wider viewing angle. Furthermore, the BRC-300 is the smallest camera in the BRC Series, making it ideal in environments that require the camera to be positioned unobtrusively.



FEATURES

Excellent Picture Quality

BRC-H700

The BRC-H700 is an HD color video camera that features three 1/3-type HD CCDs with approximately 1,120,000 total pixels. This camera is ideal for high-resolution image-capturing applications and satisfies the demands of users who require exceptional-quality video images with accurate color reproduction. In addition, the highly sensitive CCDs enable remote video shooting in environments where lighting is not ideal.

BRC-Z700

The BRC-Z700 employs three 1/4-type CMOS image sensors, boasting a resolution of 1,120,000 total pixels. This camera incorporates a newly developed DSP to make effective use of the ClearVid CMOS Sensors, which have been developed using Sony advanced semiconductor technologies. One of the advantages of the CMOS sensor is that vertical smear is minimized. The combination of the new DSP and the ClearVid CMOS Sensors allows the camera to achieve both higher resolution and higher sensitivity compared to cameras equipped with conventional CMOS sensors. Furthermore, the camera's "color masking" function allows users to adjust specific colors in the image more precisely, while the "color detail" function allows users to smooth over skin tones.

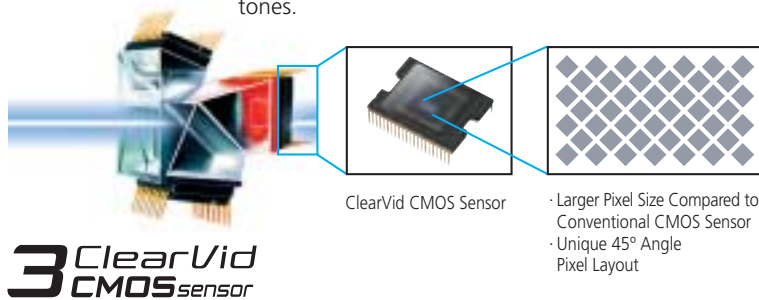

ClearVid CMOS Sensor
(vertical smear minimized)



Conventional CCD Sensor
(vertical smear)

BRC-300

The BRC-300 is equipped with three 1/4.7-type Advanced HAD CCD sensors with a total of 1,070,000 pixels. This camera delivers outstanding picture quality with high resolution and accurate color reproduction. Sony Advanced HAD technology enables this camera to produce high-quality SD images with low noise.

High Performance Pan/Tilt/Zoom Mechanism

The BRC Series of cameras covers a wide shooting range with its highly accurate Pan/Tilt mechanism. All cameras have a very wide pan range of 340 degrees and a tilt range of 120 degrees. Both pan and tilt speeds are variable within the range of 0.25 to 60 degrees per second (BRC-H700 and BRC-300) and 0.22 to 60 degrees per second (BRC-Z700). What's more, the BRC-Z700 has an extremely quiet motor that is capable of very precise movements. All BRC Series cameras are capable of capturing not only fast-moving objects, but also slow-moving objects without rocking vibration.

For capturing small or distant objects, the BRC-Z700 incorporates a 20x optical auto-focus zoom lens and the BRC-H700 and BRC-300 adopt a 12x optical zoom lens.

Versatile Video Outputs

The BRC Series offers the following outputs as standard:

Standard Video Outputs

- BRC-H700 : HD Component (Y/Pb/Pr), RGB
- BRC-Z700 : HD Component (Y/Pb/Pr), RGB, Composite, Y/C
- BRC-300/300P: Composite, Y/C

What's more, each camera in the BRC Series has a wide range of optional interface cards to choose from. This versatility allows for flexible analog and digital system configurations.

Optional Video Cards

BRC-H700

- HFBK-HD1: HD-SDI, HD Component (Y/Pb/Pr), RGB
- HFBK-SD1 : SD-SDI, Composite, Y/C, SD Component (Y/Cb/Cr), RGB
- HFBK-XG1: WXGA, XGA (Letter Box, Crop), VGA (Letter Box, Crop)
- HFBK-TS1 : i.LINK (HDV)

BRC-Z700

- BRBK-HSD1: HD-SDI, SD-SDI

BRC-300

- BRBK-301 : Composite, Y/C, SD Component (Y/Cb/Cr), RGB
- BRBK-302 : SD-SDI
- BRBK-304 : i.LINK (DV)

Optical Multiplex Unit (BRU-H700, BRU-300)

Users can transmit uncompressed digital data including external sync and camera control signals via an optical multiplex unit such as the BRU-H700 and BRU-300. With only a single cable connection between the camera and the HD optical multiplex unit, the system is extremely easy to install. The maximum cable length between these units are 500 meters for the BRC-300 and 1000 meters for both the BRC-H700 and BRC-Z700.

RS-232C/RS-422 Remote Control (VISCA protocol)

System integrators can easily configure complex systems with the BRC Series because each camera is equipped with RS-232C/RS-422 interfaces supporting the VISCA™ protocol, which allows them to be controlled by external PCs and/or controllers. All local controls such as Pan/Tilt/Zoom, camera settings, and presets can be easily accessed, and up to seven cameras can be daisy-chained.



Multiple Position Presets and User-friendly Interface

The BRC-H700 and BRC-Z700 each have sixteen presets and the BRC-300 has six presets to which predefined Pan/Tilt/Zoom positions and other parameters can be allocated. These presets can be recalled at the touch of a button to easily capture video from pre-specified areas. They can also be controlled from either the supplied IR Remote Commander Unit or optional RM-BR300 Remote Control Unit. The ergonomically designed joystick and feature-rich control panel of the RM-BR300 provide superb operability in various remote video shooting applications.

Flexible Installation

Because the BRC Series has an “Image Flip” function, the unit can either be mounted on a ceiling using the supplied ceiling mount kit or placed on a flat surface to meet the user’s installation and space requirements.

REAR PANEL LAYOUTS

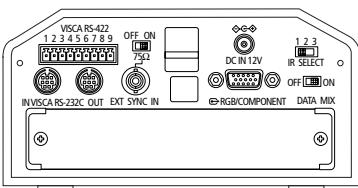

BRC-H700

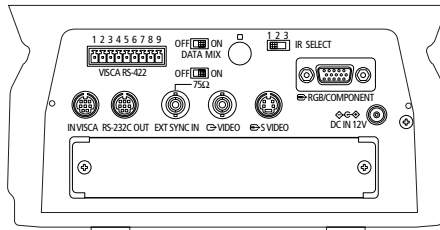

BRC-Z700

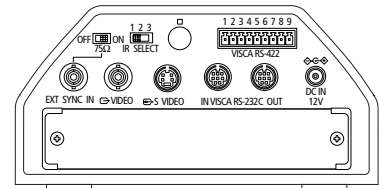

BRC-300

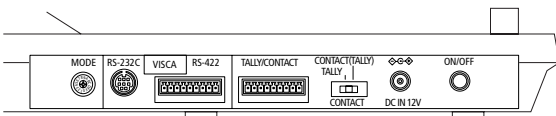

RM-BR300

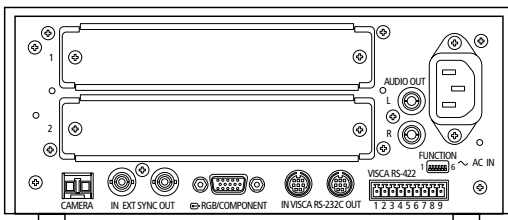

BRU-H700
HD Optical Multiplex Unit

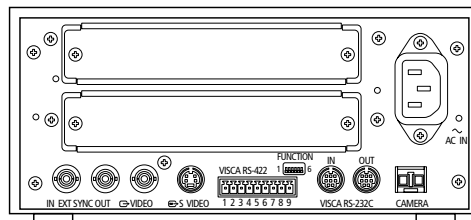

BRU-300
SD Optical Multiplex Unit

DIMENSIONS

BRC-H700

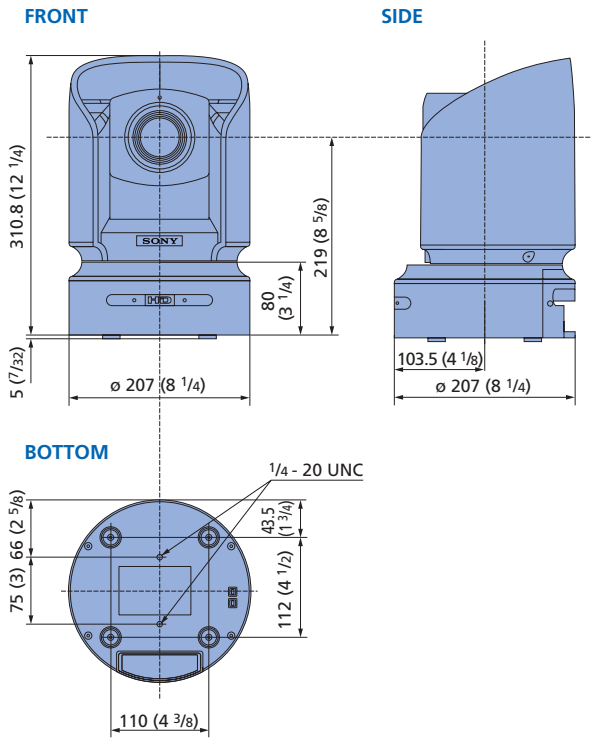

Units: mm (inches)

BRC-Z700

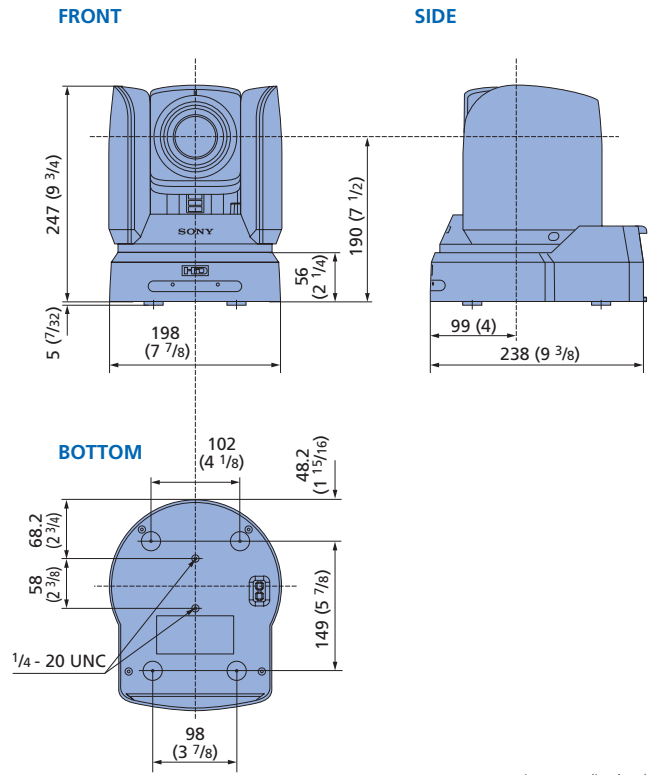

Units: mm (inches)

BRC-300/BRC-300P

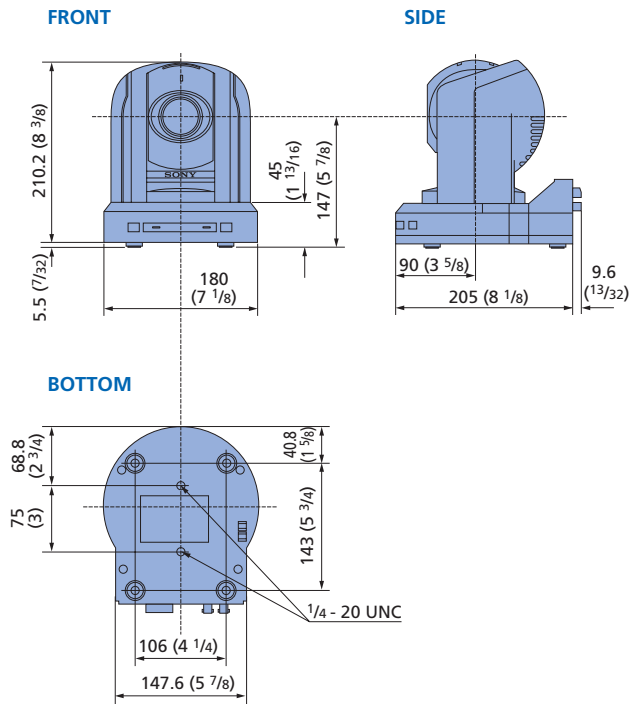

Units: mm (inches)

BRC Series Pan/Tilt Ranges

PAN RANGE

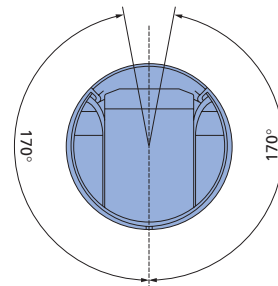

TILT RANGE

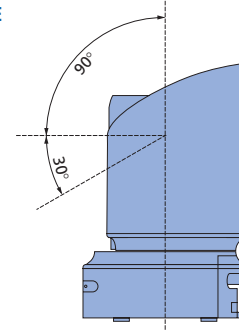

*The BRC-H700, BRC-Z700, and BRC-300/300P all have the same Pan/Tilt ranges.

SYSTEM CONFIGURATIONS

Small Scale System

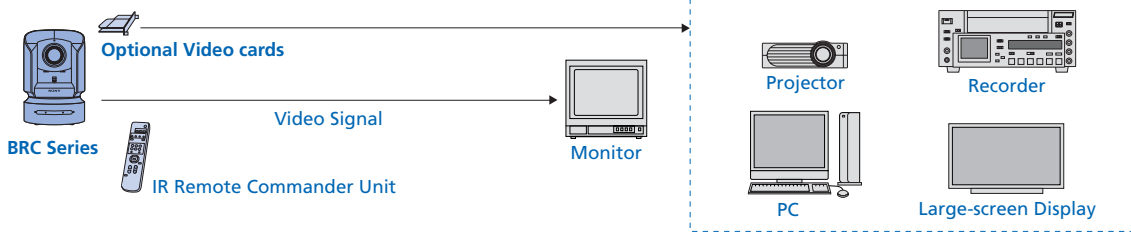

Medium-sized System

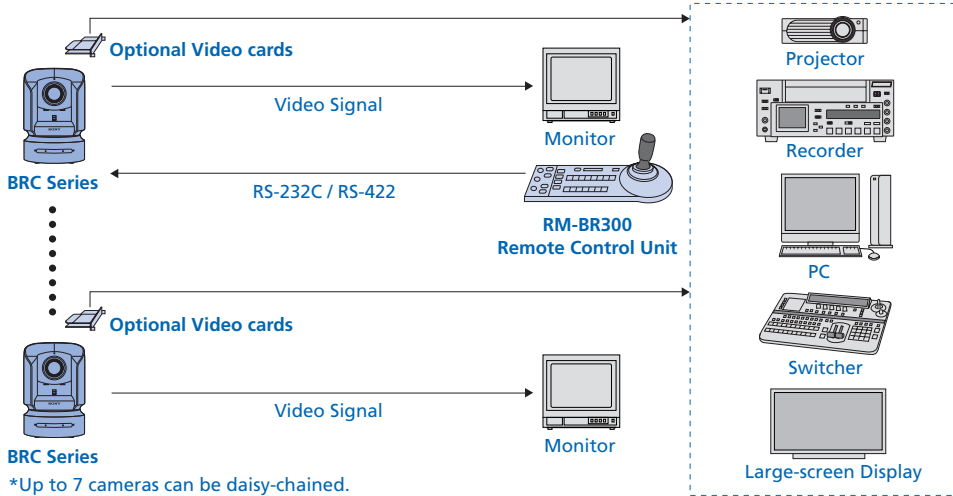

Large Scale System

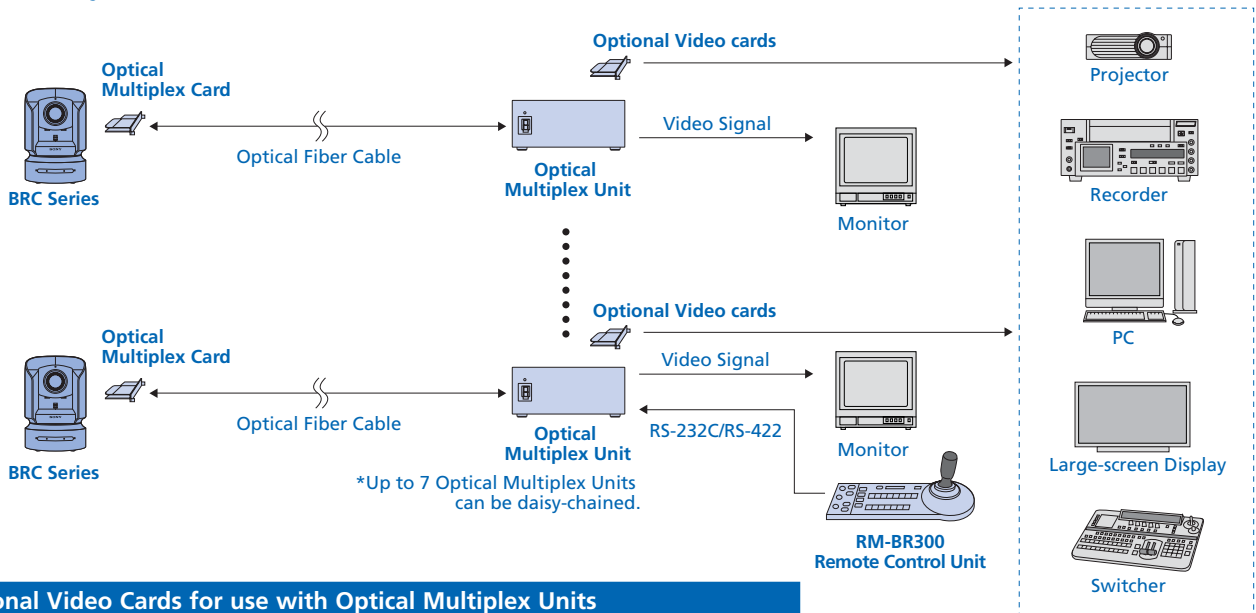

Optional Video Cards for use with Optical Multiplex Units

P/T/Z Color Video Cameras	BRC-H700	BRC-Z700	BRC-300
Optical Multiplex Cards	BRBK-H700	BRBK-MF1	BRBK-303
Optical Fiber Cables	CCFC-M100HG	CCFC-M100HG	CCFC-M100
Optical Multiplex Unit	BRU-H700	BRU-H700	BRU-300
Interface Cards	HFBK-HD1	HFBK-HD1	BRBK-301
	HFBK-SD1	HFBK-SD1	BRBK-302
	HFBK-XG1	HFBK-XG1	BRBK-304
	HFBK-TS1	HFBK-TS1	

OPTIONAL ACCESSORIES



BRBK-H700
HD Optical Multiplex Card



HFBK-HD1
HD Interface Board



HFBK-SD1
SD Interface Board



HFBK-XG1
XGA Interface Board



HFBK-TS1
i.LINK (HDV) Interface Board



BRBK-MF1
HD Optical Multiplex Card



BRBK-HSD1
HD/SD-SDI Output Card



BRBK-303
SD Optical Multiplex Card



BRBK-301
Analog RGB Component Card



BRBK-302
SDI Card



BRBK-304
DV Card



BRBK-H700 **BRC-Z700** **BRC-300**
RM-BR300
Remote Control Unit



BRC-H700 **BRC-Z700**
BRU-H700
HD Optical Multiplex Unit



BRC-300
BRU-300/BRU-300P
SD Optical Multiplex Unit



BRC-H700 **BRC-Z700**
CCFC-M100HG
Optical Fiber Cable
2-core Multi-mode Optical Fiber
Cable (100 m long), Extension Plug
Included



BRC-300
CCFC-M100
Optical Fiber Cable
2-core Multi-mode Optical Fiber
Cable (100 m long), Extension Plug
Included



CCMC-9DS*
RGB/Component, Y/C Cable
(9-pin D-sub)



CCXC-9DBS*
RGB/Component, VBS Cable
(9-pin D-sub)



BRC-Z700
VCL-HG0862
VCL-HG0862K**
Wide Conversion Lens



BRC-300
VCL-HG0737X
Wide Conversion Lens

*These cables are for use with the BRBK-301 or HFBK-SD1.

**The lens hood supplied with the VCL-HG0862K cannot be used.

SPECIFICATIONS

	BRC-H700	BRC-Z700	BRC-300	BRC-300P
Camera				
Signal systems	1080/59.94i or 1080/50i (switchable)	1080/59.94i, NTSC or 1080/50i, PAL (switchable)	NTSC	PAL
Sync systems	Internal/External			
Image device	1/3-type IT CCD x 3	1/4-type CMOS x 3	1/4.7-type CCD x 3	
Total picture elements	Approx. 1.12 Megapixels		Approx. 1.07 Megapixels	
Effective picture elements	Approx. 1.07 Megapixels		Approx. 0.69 Megapixels	
Lens	12x optical zoom (48x with digital zoom), Carl Zeiss Vario-Sonnar T* lens	20x optical zoom (80x with digital zoom), Carl Zeiss Vario-Sonnar T* lens	12x optical zoom (48x with digital zoom)	
Focal length	f=4.5 to 54 mm (F1.6 to F2.8)	f=3.9 to 78 mm (F1.6 to F2.8)	f=3.6 to 43.2 mm (F1.6 to F2.8)	
Lens filter diameter	72 mm	62 mm	37 mm	
Minimum object distance	500 mm (Wide), 800 mm (Tele)	10 mm (Wide, Limiter Off), 500 mm (Wide, Limiter On), 800 mm (Tele)	300 mm (Wide), 800 mm (Tele)	
Horizontal viewing angle	5.5 to 60.3 degrees	1.8 to 55.2 degrees	4:3 mode: 3.3 to 37.8 degrees, 16:9 mode: 4.0 to 45.4 degrees	
Focusing system	Auto/Manual			
Pan/Tilt angle	-170 to +170 degrees (Pan), -30 to +90 degrees (Tilt)			
Pan/Tilt speed	0.25 to 60 degrees/s (Pan/Tilt)	0.22 to 60 degrees/s (Pan/Tilt)	0.25 to 60 degrees/s (Pan/Tilt)	
Minimum illumination	6 lx (50 IRE, F1.6, +18 dB)	6 lx (50 IRE, F1.6, +24 dB)	7 lx (25 IRE, F1.6, +18 dB)	
Video S/N ratio	50 dB			
Shutter speed	1/10,000 to 1/60 s or 1/10,000 to 1/50 s		1/10,000 to 1/4 s	1/10,000 to 1/3 s
Gain	Auto/Manual (0 to 18 dB and Hyper Gain)		Auto/Manual (-3 to 18 dB)	
White balance	Auto/Indoor/Outdoor/One-push/Manual		Auto/Indoor/Outdoor/One-push/Manual	
Image stabilizer	On/Off (Optical)		-	
Image flip	On/Off			
ND filter	ND1/ND2/Off	-	-	
Presets positions	16		6	
Interfaces				
HD video output	D-Sub 15 pin: Component (Y/Pb/Pr) or RGB, HD, VD or SYNC		-	
SD video output	-	BNC: Composite, Mini DIN 4 pin : Y/C	BNC: Composite (NTSC), Mini DIN 4 pin: Y/C	BNC: Composite (PAL), Mini DIN 4 pin : Y/C
External Sync input	BNC			
Camera control	Mini DIN 8 pin: RS-232C (VISCA IN), Mini DIN 8 pin: RS-232C (VISCA OUT), Connector plug 9 pin: RS-422 (VISCA IN/OUT)			
General				
Operating temperature	0 to 40 degrees (32 to 104 °F)			
Storage temperature	-20 to 60 degrees (-4 to 140 °F)			
Power requirements	DC 10.8 to 13.2 V			
Power consumption	Max. 24 W (without optional cards)	Max 28.8 W (without optional cards)	Max. 21.6 W (without optional cards)	
Dimensions (W x H x D)	207 x 310.8 x 207 mm (8 1/4 x 12 1/4 x 8 1/4 inches)	198 x 247 x 238 mm (7 7/8 x 9 3/4 x 9 3/8 inches)	180 x 210.1 x 205 mm (7 1/8 x 8 3/8 x 8 1/8 inches)	
Mass	4.5 kg (9 lb 15 oz)		2.5 kg (5 lb 8 oz)	
Supplied accessories	IR Remote Commander Unit, AC power adaptor, AC power cord, RS-422 connector plug, Ceiling bracket x2, Wire rope, Screws, Operating instructions			

	BRU-H700	BRU-300	BRU-300P
Interfaces			
Optical fiber connector	LC Duplex Fiber Connector		
HD video output	D-Sub 15 pin: Component (Y/Pb/Pr) or RGB, HD, VD or SYNC	-	-
SD video output	-	BNC: Composite (NTSC), Mini DIN 4 pin: Y/C	BNC: Composite (PAL), Mini DIN 4 pin: Y/C
External sync input	BNC		
External sync output	BNC		
Audio line output	Phono jack x2 (L/R)	-	
Camera control	Mini DIN 8 pin: RS-232C (VISCA IN), Mini DIN 8 pin: RS-232C (VISCA OUT), Connector plug 9 pin: RS-422 (VISCA IN/OUT)		
Optional card slots	2 slots	2 slots (When both slots are used simultaneously, the interface cards must be of two different types.)	
General			
Operating temperature	0 to 40 degrees (32 to 104 °F)		
Storage temperature	-20 to 60 degrees (-4 to 140 °F)		
Power requirements	AC 100 to 240 V (50/60 Hz)		
Power consumption	Max. 10 W (without optional cards)	Max. 9 W (without optional cards)	
Dimensions (W x H x D)	210 x 86 x 240 mm (8 3/8 x 3 1/2 x 9 1/2 inches)	212 x 88 x 210 mm (8 3/8 x 3 1/2 x 8 3/8 inches)	
Mass	2.4 kg (5 lb 5 oz)		2.1 kg (4 lb 10 oz)
Supplied accessories	AC power cord, RS-422 connector plug, RS-232C cable (3 m, Mini DIN 8 pin), Operating instructions		

	HFBK-HD1	HFBK-SD1	HFBK-XG1	HFBK-TS1
Video output	D-Sub 15 pin: Component (Y/Pb/Pr) or RGB, HD, VD or SYNC BNC x2: HD-SDI	D-Sub 9 pin: Component (Y/Pb/Pr) or RGB, Composite or Y/C, SYNC BNC: Composite BNC: SD-SDI	D-Sub 15 pin: RGB, HD, VD (WXGA/XGA/VGA)	i.LINK 6 pin: HDV OUT (IEEE1394 S100)
Audio line input				Phono jack x2 (L/R)

	BRBK-HSD1	BRBK-301	BRBK-302	BRBK-304
Video output	BNC x2: HD-SDI or SD-SDI	D-Sub 9 pin: Component (Y/Pb/Pr) or RGB, Composite or Y/C, SYNC	BNC: SD-SDI	i.LINK 6 pin: DV OUT (IEEE1394 S100)

Distributed by

©2007 Sony Corporation. All rights reserved.

Reproduction in whole or in part without written permission is prohibited. Design, features, and specifications are subject to change without notice.

All non-metric weights and measurements are approximate.

Some images in this catalog are simulated.

Sony is a registered trademark of Sony Corporation.

Advanced HAD, VISCA, Remote Commander, ClearVid CMOS, i.LINK, and the

i.LINK logo are trademarks of Sony Corporation

HDV and the HDV logo are trademarks of Sony Corporation and Victor

Company of Japan, Limited.

Vario-Sonnar T* is a trademark of Carl Zeiss AG.