

INTRODUCTION

Designed to comply with the pin-out of Sony's discontinued XC-55BB camera, Sony's new two piece, black and white progressive scan video camera - the XC-56BB - incorporates a 1/3-type progressive scan CCD that produces detailed, VGA resolution images at a high frame rate (30 fps). Designed in a miniature body, the new XC-56BB camera inherits all the outstanding features of the XC-56 camera, but it is "form fitted" to the XC-55BB camera body.



FEATURES

- 1/3 inch Progressive Scan CCD with square pixels
- Non-TV format
- Square lattice/Full pixel read-out
- Effective Picture Elements - 659 (H) x 494 (V)
- NF Lens Mount
- High Rate Scan /Binning Function - 30 frames per sec./60 frames per sec. Binning
- Sync System - Internal/External (auto)
- External Sync System - HD/VD (2 to 5 Vp-p)
- Gain - Manual/Fixed switchable
- Gamma - OFF ($\gamma=1$)
- High Shock and Vibration Resistance
- Miniature Size
- External Trigger Shutter: 1/4 to 1/100,000 sec
- Cable length: 2 m
- Lead-free soldering
- Same Pin Assignment as XC-55BB camera

like.no.other™

XC-56BB

B/W Progressive Scan CCD
Remote Head Video Camera

www.sonybiz.net/vision



CONNECTION DIAGRAM

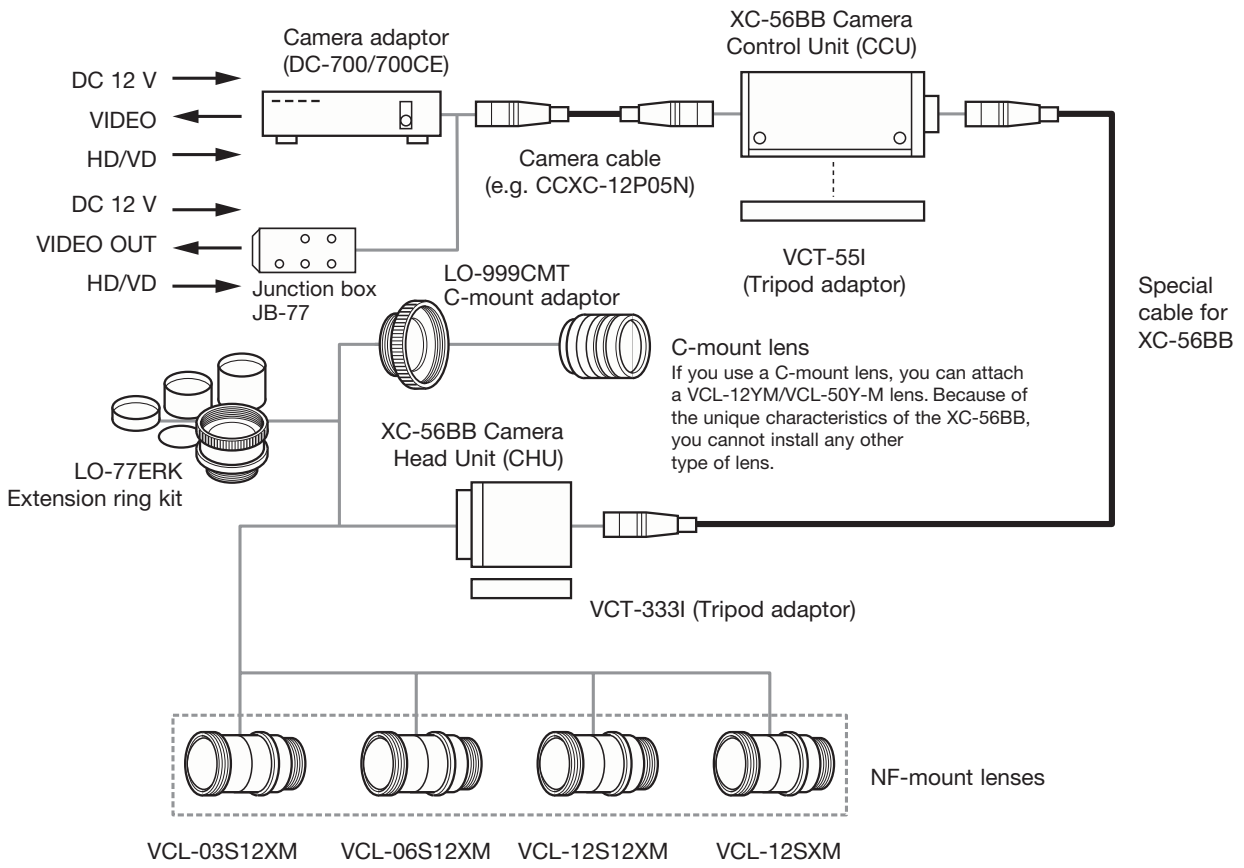

LOCATION AND FUNCTION OF PARTS AND CONTROLS

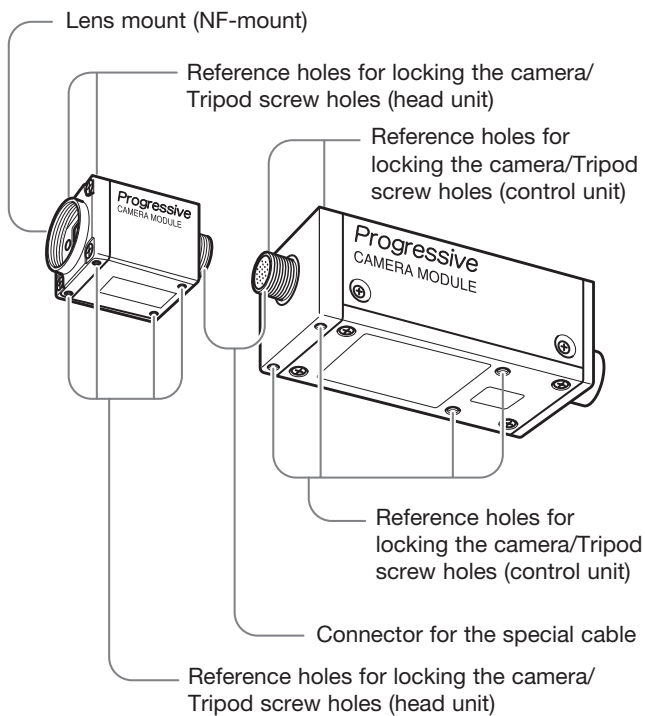

REAR PANEL

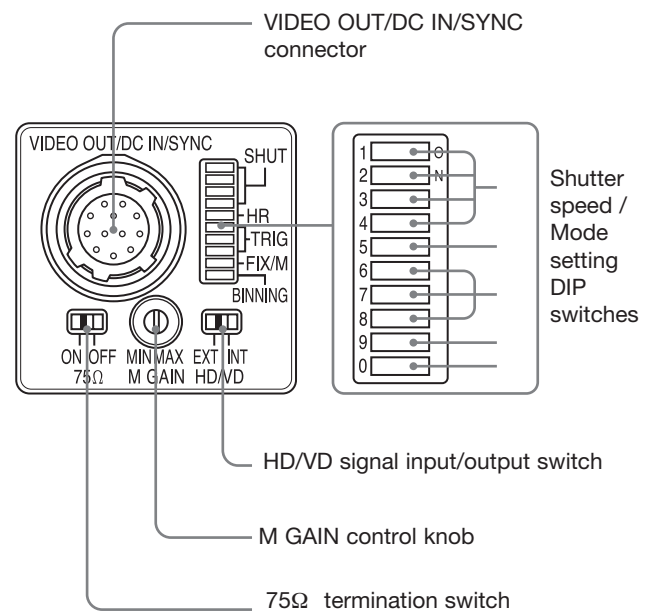

ELECTRONIC SHUTTER

There are two shutter types: normal shutter and external trigger shutter. Select them with the DIP switches on the rear panel.

Normal Shutter	Other Modes*
8 <input type="checkbox"/>	8 <input type="checkbox"/>

NORMAL SHUTTER

This mode provides continuous video output with the electronic shutter selected by switches to capture a high-speed moving object clearly.

* "Other modes" refers to restart/reset mode and external trigger shutter mode.

Normal Shutter Speed Settings

1/100	1/125	1/250	1/500	1/1000
1 <input type="checkbox"/>	1 <input type="checkbox"/>	1 <input type="checkbox"/>	1 <input type="checkbox"/>	1 <input type="checkbox"/>
2 <input type="checkbox"/>	2 <input type="checkbox"/>	2 <input type="checkbox"/>	2 <input type="checkbox"/>	2 <input type="checkbox"/>
3 <input type="checkbox"/>	3 <input type="checkbox"/>	3 <input type="checkbox"/>	3 <input type="checkbox"/>	3 <input type="checkbox"/>
4 <input type="checkbox"/>	4 <input type="checkbox"/>	4 <input type="checkbox"/>	4 <input type="checkbox"/>	4 <input type="checkbox"/>
1/2000	1/4000	1/8000	1/15000	
1 <input type="checkbox"/>	1 <input type="checkbox"/>	1 <input type="checkbox"/>	1 <input type="checkbox"/>	
2 <input type="checkbox"/>	2 <input type="checkbox"/>	2 <input type="checkbox"/>	2 <input type="checkbox"/>	
3 <input type="checkbox"/>	3 <input type="checkbox"/>	3 <input type="checkbox"/>	3 <input type="checkbox"/>	
4 <input type="checkbox"/>	4 <input type="checkbox"/>	4 <input type="checkbox"/>	4 <input type="checkbox"/>	

EXTERNAL TRIGGER SHUTTER

Inputting an external trigger pulse enables the camera to capture fast-moving objects clearly. Set DIP switches 6, 7, and 8 on the rear panel to Mode 1 or Mode 2. When you set the trigger pulse width to 1/3 of a second or more, the output signal changes to the normal VIDEO signal.

Mode 1	Mode 2
6 <input type="checkbox"/>	6 <input type="checkbox"/>
7 <input type="checkbox"/>	7 <input type="checkbox"/>
8 <input type="checkbox"/>	8 <input type="checkbox"/>

OFF	ON
5 <input type="checkbox"/>	5 <input type="checkbox"/>

RESTART/RESET MODE

This mode allows you to capture the information on single screens at any time by externally inputting restart/reset signals (HD/VD). To enter this mode, set the trigger shutter switches (6 to 8) on the rear panel of the camera.

R/R
6 <input type="checkbox"/>
7 <input type="checkbox"/>
8 <input type="checkbox"/>

OFF	ON
5 <input type="checkbox"/>	5 <input type="checkbox"/>

LONG EXPOSURE

The Restart/Reset function extends the CCD accumulation time, resulting in highly sensitive image capture. This function is effective when you cannot gain satisfactory sensitivity under normal operating conditions, or when you want to observe the trail of a moving object. Extend the VD interval (T) between external VD pulses.

Example of input timing chart

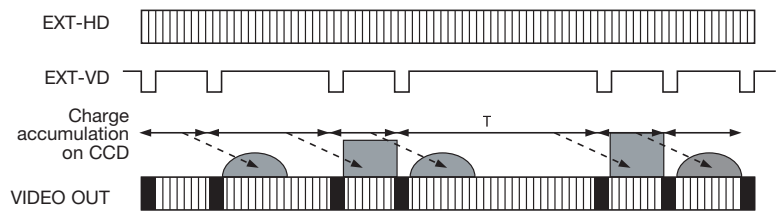

SPECTRAL SENSITIVITY CHARACTERISTICS

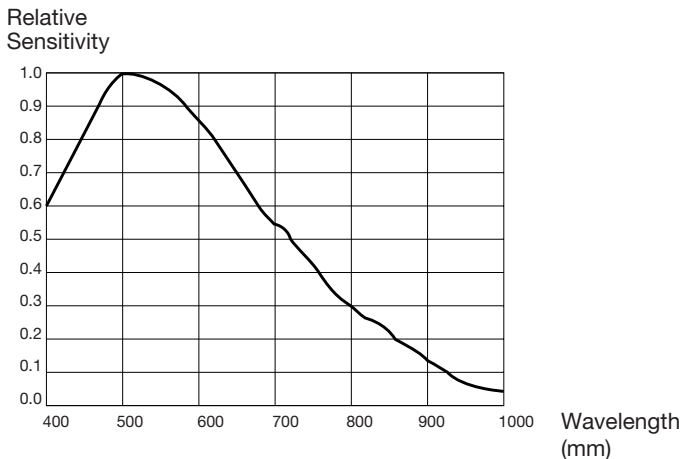

(Lens characteristics included, and light source characteristics excluded.)

PIN ASSIGNMENT

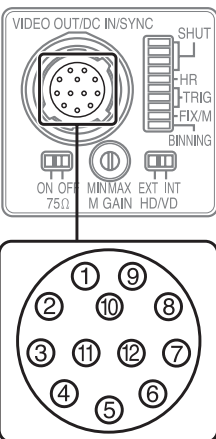

Pin No.	Camera sync output	External mode (HD/VD)	Restart/Reset	External trigger splitter
1	Ground	Ground	Ground	Ground
2	+12 V DC	+12 V DC	+12 V DC	+12 V DC
3	Video output (Ground)	Video output (Ground)	Video output (Ground)	Video output (Ground)
4	Video output (Signal)	Video output (Signal)	Video output (Signal)	Video output (Signal)
5	HD output (Ground)	HD input (Ground)	HD input (Ground)	HD input (Ground)
6	HD output (Signal)	HD input (Signal)	HD input (Signal)	HD input (Signal)
7	VD output (Signal)	VD input (Signal)	Reset (Signal)	VD input (Signal)
8	—	—	—	—
9	—	—	—	Trigger pulse input (Signal)
10	—	—	—	—
11	—	—	—	—
12	VD output (Ground)	VD input (Ground)	Reset (Ground)	VD input (Ground)

OPTIONAL ACCESSORIES

Compact camera adaptor	DC-700/700CE
12-pin Camera Cable	CCXC-12P02N (2 m) CCXC-12P10N (10 m) CCXC-12P05N (5 m) CCXC-12P25N (25 m)
C-mount adaptor	LO-999CMT
C-mount lens	VCL-12YM VCL-50YM
NF-mount lens	VCL-03S12XM VCL-12S12XM VCL-06S12XM VCL-12SXM
Tripod adaptor	VCT-333I (for CHU) VCT-55I (for CCU)

XC-56BB SPECIFICATIONS

Image Device	1/3 type Progressive Scan CCD
Effective Pixel Elements (HxV)	659 X 494
Effective Lines (HxV)	647 X 493
Output Image Size	VGA class (647 x 494)
Cell Size (HxV)	7.4 x 74.4 μm
Lens Mount	NF mount
Flange Focal Length	12.0 mm
Sync System	Internal/External (automatically switched according to input signal)
External Synchronisation Input / Output	HD/VD (HD/VD level: 2 to 5 Vp-p)
Allowable Frequency Deviation of External Synchronisation	± 1% (in horizontal synchronous frequency)
H Jitter	Less than 20 ns
Scan Lines	525-lines/236-lines (Normal mode/Binning mode)
Video OutputMode	Normal: 1-line sequential output 29.97 fps / Binning: F2-line sequential output 59.94 fps
Video Output	1.0 Vp-p, sync. Negative, 75 Ω, unbalanced
Horizontal Frequency	15,734 KHz
Output Signal Frequency	29.97 Hz (Normal mode)/59.94 Hz (Binning Mode)
Horizontal Resolution	500 TV lines
Sensitivity	400 lx (F8, y= OFF, FIX GAIN (0dB)
Minimum Illumination	0.5 lx (F1.4, y= OFF, GAIN + 18dB)
S/N Ratio	58 dB
Gain	Fixed/Manually Adjustable
Gamma	1 (fixed)
White Clip	820 mV ± 70mV
Shutter Mode	Normal Shutter, Restart/Reset, External Trigger shutter mode (Mode1/Mode2)
Normal Shutter Speed	1/100, 1/125, 1/250, 1/500, 1/1000, 1/2000, 1/4000, 1/8000, 1/15000 s
External Trigger Shutter	DIP switch setting 1/100, 1/125, 1/250, 1/500, 1/1000, 1/2000, 1/4000, 1/8000, 1/10000 s, 1/25000, 1/50000, 1/100000 s Trigger pulse width settings: 1/4 to 1/100000 s
External Trigger	Polarity: +, 2μs to 250 ms ; Input impedance: 10kΩ or more (H:-2 to 5.0V, L: 0 +0.6V)
Pin Assignment	Correspondence to EIAJ compliant 12PIN connector pin assignment Unavailable (No.8 pin: Trigger input (G), No.9 pin: Trigger input, No. 10 pin: GRD, No. 11 pin: + 10V) Pins No.10 and 11 are not connected inside the camera
Power Requirements	+12 V DC (range: +10.5 to 15V)
Power Consumption	2.2 W
Dimensions (WxHxD)	CHU: 22 x 22 x 30 mm CCU: 29 x 29 x 67 mm
Mass	CHU: Approximately 40g CCU: Approximately 100g
Operating Temperature	-5 to 45°C
Storage Temperature	-30 to 60°C
Performance Guarantee Temperature	0 to 40°C
Operating Humidity	20 to 80% (no condensation)
Storage Humidity	20 to 95% (no condensation)
Vibration Resistance	10G (20Hz to 200Hz)
Shock Resistance	70 G
MTBF	73,800 Fit (approx. 8.4 years)
Regulation	UL 6500, FCC Class A Digital Device, CE (EN61326/97 + A1/98)
Supplied Accessories	Lens mount cap (1), Operating Instructions (1), Dedicated cable (1), Ferrite core (1)

DIMENSIONS

Unit: mm (inch)

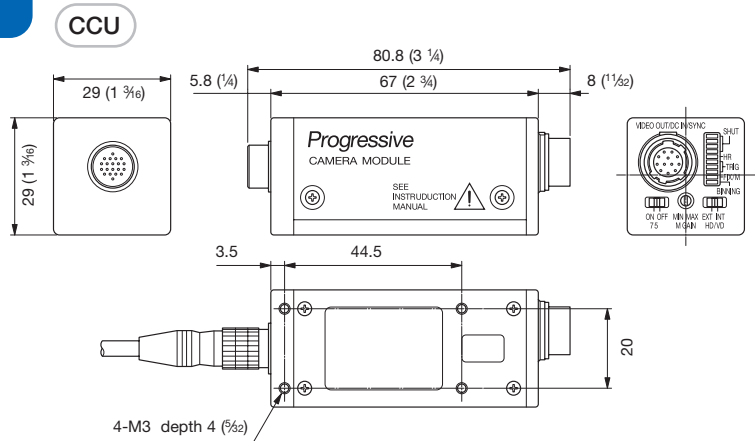
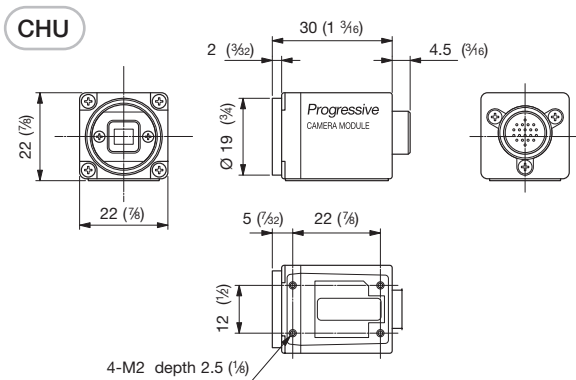

©2005 Sony Corporation. All rights reserved.
Reproduction in whole or in part without written permission is prohibited.
Design, features and specifications are subject to change without notice.
All non-metric weights and measurements are approximate.
Sony and "Like.no.other" are registered trademarks of Sony Corporation.
All other trademarks are the property of their respective owners.
CA XC-56BB/GB- / 2005