

XC-HR50 XC-HR57

Progressive Scan	^{*1} 1/3 Type CCD	^{*2} 1/2 Type CCD	Square Pixels	C Lens Mount	HD/VD External Sync	1/60 sec 1K Non-Interface	
High-Rate Scanning Output	VS Output	VGA Output	Mode 1 (Non-Reset Mode) External Trigger Shutter	Mode 2 (Non-Reset Mode) External Trigger Shutter	Restart Reset	Long Exposure	
Lead-Free Solder						*1 :XC-HR50	*2 :XC-HR57



Outline

The XC-HR50 and XCHR57 are monochrome camera modules with full pixel read-out. The XC-HR50 incorporates a 1/3 type double scan CCD, and the XC-HR57 incorporates a 1/2 type double scan CCD. Both cameras have VGA resolution (648 (H) x 494 (V)) output at 60 frames/sec, making them ideal for high-speed image capturing. Relying on high-density mounting technology, these cameras are the same size as other Sony cameras in the XC-HR series and XC-E series, which increases their mechanical compatibility. These ultra-compact (29 (W) x 29 (H) x 30 (D) mm) double-speed progressive scan cameras are also lightweight and have a short tact time.

Features

- XC-HR50:1/3 Type PS CCD
XC-HR57:1/2 Type PS CCD
 - Double Scan CCD
 - The CCD has square pixels eliminating the need for aspect ratio conversion.
 - XGA resolution (648 x 494 pixels) image capturing at a speed of 60 frames/sec.
- High-rate scanning (at restart/reset ON, Binning OFF)
Up to 240 frames/sec. (Effective line: 100 lines)
- Compact and lightweight
29 (W) x 29 (H) x 30 (D) mm, 50 g
- External trigger shutter 1/4 to 1/100,000 sec.
- Electronic Shutter 1/100 to 1/20,000 sec.
- Synchronization Internal/External (HD/VD)
- C-mount system
- High shock and vibration tolerant

Accessories

- Compact camera adaptor
 - DC-700/700CE
- 12-pin camera cable (GE standard)
 - CCXC-12P02N (2 m)
 - CCXC-12P05N (5 m)
 - CCXC-12P10N (10 m)
 - CCXC-12P25N (25 m)
- Tripod adaptor
 - VCT-333I
- C-mount LENS
 - VCL-08YM
 - VCL-12YM
 - VCL-16YM
 - VCL-25YM
 - VCL-50YM

Dimensions

Camera body of all XC-HR models

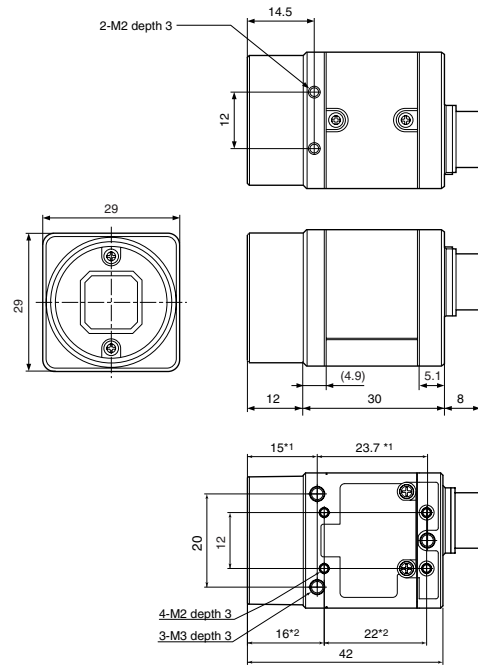

*1: for 3-M3 screw
*2: for 4-M2 screw

Unit: mm

Spectral Sensitivity Characteristics

●XC-HR50/HR57 (Typical Values)

Relative sensitivity

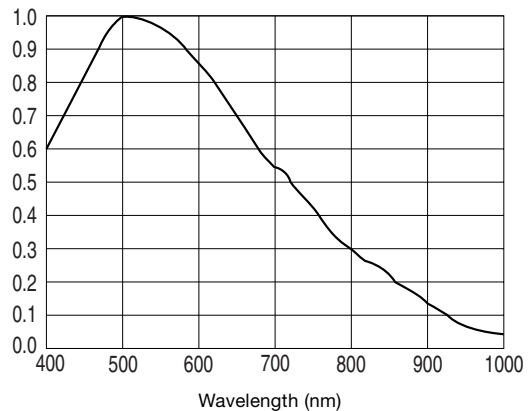

(Lens characteristics included, and light source characteristics excluded.)

Location and Function of Parts and Controls

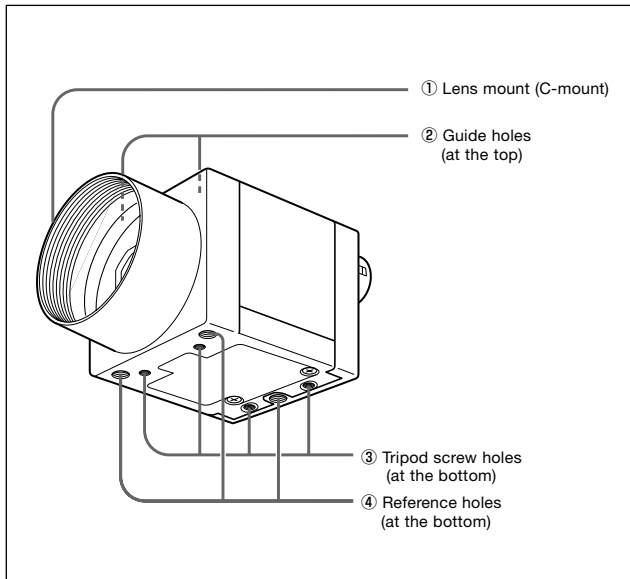

① Lens mount (C-mount)

Attach any C-mount lens, such as the VCL-12YM standard lens, or other optical equipment.

Note

Be sure that the lens does not project more than 7mm from the lens mount.

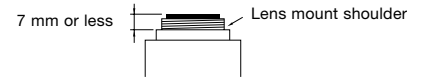

② Guide holes (at the top)

These screw holes help to lock the camera module.

③ Tripod screw holes (at the bottom)

These four screw holes on the bottom are for installing the camera module on a tripod. To install on a tripod, you will need to install the VCT-333I tripod adaptor using these holes on the bottom of the camera.

④ Reference holes (at the bottom)

These precision screw holes are for locking the camera module. Locking the camera module using these holes secures the optical axis alignment.

Specifications

	XC-HR50	XC-HR57
Image device	1/3 type progressive scan IT CCD	1/2 type progressive scan IT CCD
Effective picture elements	659 (H) x 494 (V)	
Effective lines	648 (H) x 494 (V)	
Image size	VGA size : 648 (H) x 494 (V)	
Cell size	7.4 μm (H) X 7.4 μm (V)	9.9 μm (H) X 9.9 μm (V)
Lens mount	C mount	
Sync system	Internal/External (auto)	
External sync signal input/output*1	HD/VD (HD/VD level: 2 to 5 Vp-p, 75Ω)	
External sync allowable frequency	±1 % (in horizontal sync frequency)	
Jitter	Less than 20 ns	
Scanning system	Non-interlace Progressive scan	
Output signal frequency	Binning: 2-line combined output 120 fps/ Normal: 1-line sequential output 60 fps	
Video output	1.0 Vp-p, sync negative, 75 Ω, unbalanced	
CCD vertical drive frequency	31.468 kHz	
CCD horizontal drive frequency	59.94 MHz (normal mode), 119.88 Hz (binning mode)	
Horizontal resolution	500 TV lines	
Sensitivity	400 lx F5.6 (γ=OFF, FIX GAIN (0 dB))	
Minimum illumination	1 lx (F1.4, γ=OFF, GAIN +18 dB)	
S/N ratio	58 dB (0 dB GAIN)	
Gain	Manual (0 to 18 dB)/Fix (0 dB) (adjustable on the rear panel)	
Gamma	OFF (fixed)	
White clip	820 mV ±70 mV (F1.4, FIX GAIN (0 dB))	
Shutter	Normal shutter, Restart/Reset, External trigger shutter (Mode 1/Mode 2)	
Normal shutter speed	1/100, 1/125, 1/250, 1/500, 1/1,000, 1/2,000, 1/4,000, 1/10,000, 1/15,000, 1/30,000 s	
External trigger shutter speed	DIP switch settings: 1/100, 1/125, 1/250, 1/500, 1/1,000, 1/2,000, 1/4,000, 1/10,000, 1/25,000, 1/50,000, 1/100,000 s Trigger pulse width settings: 1/4 to 1/100,000 s	
External trigger	Polarity: +, Width: 2 μs to 250 ms, Input impedance: 10kΩ or more	
High-rate scanning	R/R mode binning off: max 240 frames/s (effective line: 102 lines) binning on: max 362 frames/s (effective line: 59 lines) External trigger shutter mode (MODE 1) binning off: max 240 frames/s (effective line: 100 lines) binning on: max 362 frames/s (effective line: 57 lines)	
Power requirements	DC 12 V (+10.5 V to +15.0 V)	
Power consumption	1.8 W	
Dimensions	29 (W) x 29 (H) x 30 (D) mm	
Mass	50 g	
Operating temperature	-5 to 45 °C	
Storage temperature	-30 to 60 °C	
Performance guarantee temperature	0 to 40 °C	
Operating humidity	20 to 80 % (no condensation)	
Storage humidity	20 to 95 % (no condensation)	
Vibration resistance	10 G (20 Hz to 200 Hz)	
Shock resistance	70 G	
MTBF	88,044 hrs.	
Regulation	UL 6500, FCC Class A Digital Device, CE (EN61326/97+A1/98), Australia EMC (AS4251.1+A4252.1)	
Supplied accessories	Lens mount cap (1), Operating instructions (1)	

*1 Automatic switching in response to the presence of an input signal when the switch on the rear panel is set to EXT.

Rear Panel

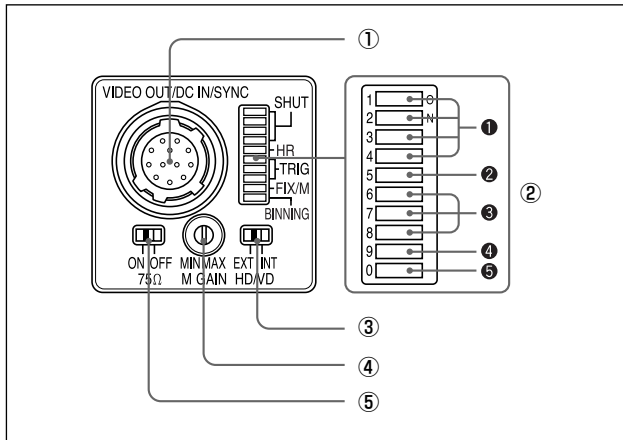

Note

Be sure to turn the power off before making switch settings. As the variable controller for manual adjustment is a small precise component, do not apply force more than required when adjusting. Doing so will break the component. The controller is not a 360-degree rotation type. Do not turn the controller beyond the stopper of the component. The range of rotation is about 260 degrees. For the adjustment of the variable controller, use a flathead screwdriver. The sizes of a recommended flathead screwdrivers are 1.9mm width, 0.5mm thickness and more than 0.45mm length.

① VIDEO OUT/DC IN/SYNC (video output/DC power/sync input signal) connector (12-pin connector)

Connect a CCXC-12P05N camera cable to this connector to obtain power from the +12V DC power supply and also to enable video signal output from the camera module. When a sync signal generator is connected to this connector, the camera module is synchronized with the external sync signals (HD/VD signals).

② Shutter speed/Mode setting DIP switch

① Shutter speed (bits 1-4)

Set an appropriate shutter speed (factory setting: OFF).

② High-rate scan mode switch (bit 5)

The factory setting of this switch is high-rate scan OFF. If you turn this switch ON to use high-rate scan mode, you also need to make the external VD pulse rate and width settings.

③ Restart reset/External trigger shutter mode switch (bits 6 to 8)

By inputting an external restart/reset signal, you can capture the information of single screens at arbitrary timing. By inputting an external trigger signal, you can capture fast-moving objects at precise locations. The factory settings for these switches are for normal operation (restart/reset and external trigger shutter OFF).

④ Gain switch (bit 9)

This switch selects FIX (fixed) or MANUAL (manual adjustment) (factory setting: FIX (left side)).

⑤ Binning mode switch (bit 0)

Switches the video signal output mode between binning OFF and binning ON (factory setting: OFF).

③ HD/VD signal input/output switch

Set the switch to INT to output HD/VD signals from the camera module.

Set the switch to EXT to input HD/VD signals from an external unit (factory setting: EXT).

Note

Even when the switch is set to EXT, the camera module operates in internal synchronization mode when no external HD signal is input. In this case, however, the camera module will not output internal sync signals.

④ M Gain (Manual Gain) control knob

If you have selected MANUAL (manual adjustment) with DIP switch 4, this knob adjusts the gain.

⑤ 75Ω termination switch

Turn this to OFF when not terminating the external sync signal (factory setting: ON).

Factory Mode Settings of Rear Panel

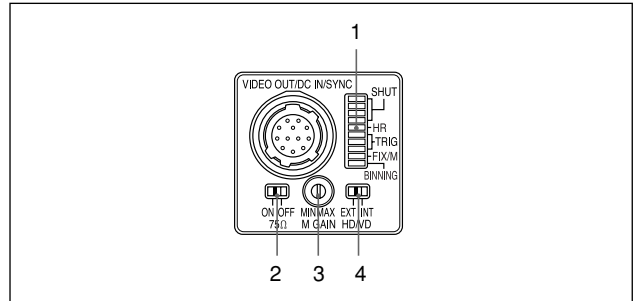

Number	Switch name	Factory mode setting
1	Shutter speed and mode setting DIP switches	All bits are OFF (left).
2	75Ω termination switch	ON
3	M GAIN control knob	— *
4	HD/VD signal input/output switch	EXT

* This unit is shipped from the factory with the gain switch (DIP switch 9) being set to "FIX", so the M GAIN control knob is not operative unless the switch setting is changed. When the gain switch (DIP switch 9) is set to MANUAL, you can rotate this knob to adjust gain over the range 0 to 18 dB.

Connector Pin Assignments

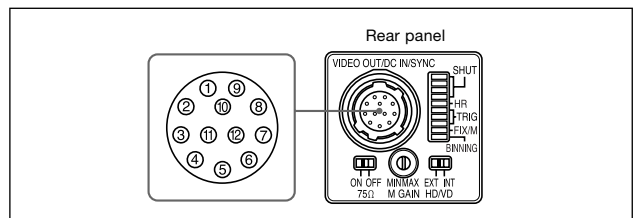

Pin No.	Camera sync output	External mode (HD/VD)	Restart/Reset	External trigger shutter
1	Ground	Ground	Ground	Ground
2	+12V DC	+12V DC	+12V DC	+12V DC
3	Video output (Ground)	Video output (Ground)	Video output 1 (Ground)	Video output (Ground)
4	Video output (Signal)	Video output (Signal)	Video output 1 (Signal)	Video output (Signal)
5	HD output (Ground)	HD input (Ground)	HD input (Ground)	HD input (Ground)
6	HD output (Signal)	HD input (Signal)	HD input (Signal)	HD input (Signal)
7	VD output (Signal)	VD input (Signal)	Reset (Signal)	VD input (Signal)
8	—	—	—	—
9	—	—	—	—
10	—	—	—	WEN output (Signal)
11	—	—	—	Trigger pulse input (Signal)
12	VD output (Ground)	VD input (Ground)	Reset (Ground)	Reset (Ground)*

* Common ground for pins 7, 10, and 11

About the Electronic Shutter

There are two shutter types: normal shutter and external trigger shutter. Select them with the DIP switches on the rear panel.

* The electronic shutter cannot be used in restart/reset mode. High-rate scan can be used in restart/reset mode and in external trigger shutter mode 1.

Normal Shutter

This mode provides continuous video output with the electronic shutter selected by switches to capture a high-speed moving object clearly.

Normal Shutter	Other modes*
8 <input type="checkbox"/>	8 <input type="checkbox"/>

* "Other modes" refers to restart/reset mode and external trigger shutter mode.

●Normal shutter speed settings

1/125	1/250	1/500	1/1000
1 <input type="checkbox"/> 2 <input type="checkbox"/> 3 <input type="checkbox"/> 4 <input type="checkbox"/>	1 <input type="checkbox"/> 2 <input type="checkbox"/> 3 <input type="checkbox"/> 4 <input type="checkbox"/>	1 <input type="checkbox"/> 2 <input type="checkbox"/> 3 <input type="checkbox"/> 4 <input type="checkbox"/>	1 <input type="checkbox"/> 2 <input type="checkbox"/> 3 <input type="checkbox"/> 4 <input type="checkbox"/>
1/2000	1/4000	1/10000	1/15000
1 <input type="checkbox"/> 2 <input type="checkbox"/> 3 <input type="checkbox"/> 4 <input type="checkbox"/>	1 <input type="checkbox"/> 2 <input type="checkbox"/> 3 <input type="checkbox"/> 4 <input type="checkbox"/>	1 <input type="checkbox"/> 2 <input type="checkbox"/> 3 <input type="checkbox"/> 4 <input type="checkbox"/>	1 <input type="checkbox"/> 2 <input type="checkbox"/> 3 <input type="checkbox"/> 4 <input type="checkbox"/>
1/30000	1/100		
1 <input type="checkbox"/> 2 <input type="checkbox"/> 3 <input type="checkbox"/> 4 <input type="checkbox"/>	1 <input type="checkbox"/> 2 <input type="checkbox"/> 3 <input type="checkbox"/> 4 <input type="checkbox"/>		

(Unit: seconds)

External Trigger Shutter

Mode 1	Mode 2
6 <input type="checkbox"/> 7 <input type="checkbox"/> 8 <input type="checkbox"/>	6 <input type="checkbox"/> 7 <input type="checkbox"/> 8 <input type="checkbox"/>

High-rate scanning

OFF	ON
5 <input type="checkbox"/>	5 <input type="checkbox"/>

(High-rate mode is compatible with Mode 1 only.)

Inputting an external trigger pulse enables the camera to capture first-moving objects clearly.

Set DIP switches 6, 7, and 8 on the rear panel to Mode 1 or Mode 2. When you set the trigger pulse width to 1/3 of a second or more, the output signal changes to the normal VIDEO signal.

Note

High-rate scan mode cannot be used while in external trigger shutter mode 2.

There are two modes for the timing in which video signals are obtained.

●Mode 1 (Non-reset mode)

- In this mode, a video signal synchronized with a VD signal is output after a trigger pulse is input.
- The video signal is synchronized with the external VD signal when an external HD*/VD signal is input.
- The video signal is synchronized with an internal VD signal when no external HD*/VD signal is input.

* External or internal synchronization is selected automatically depending on the presence or absence of external HD input.

●Mode 2 (Reset mode)

In this mode, an internal VD is reset, then a video signal is output a certain period of time after trigger pulse input.

To Set the External Trigger Shutter

There are two ways to set the shutter speed.

●Using trigger pulse width

Set all DIP switches (1 to 4 on the rear panel) to OFF. You can obtain an arbitrary shutter speed by setting the trigger pulse width to the range of 2 μ sec to 250 msec. Exposure time = Trigger pulse width + 6 μ sec

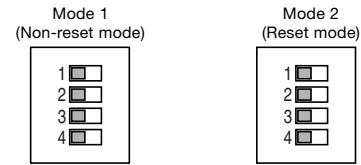

Note

An incorrect video signal will be output if you input a new trigger pulse before the video signal output for the previous trigger pulse is output completely.

●Using the DIP switches on the rear panel

For shutter speeds, see the following table.

Mode 1 (Non-reset mode)/Mode 2 (Reset mode)

1/125	1/250	1/500	1/1000
1 <input type="checkbox"/> 2 <input type="checkbox"/> 3 <input type="checkbox"/> 4 <input type="checkbox"/>	1 <input type="checkbox"/> 2 <input type="checkbox"/> 3 <input type="checkbox"/> 4 <input type="checkbox"/>	1 <input type="checkbox"/> 2 <input type="checkbox"/> 3 <input type="checkbox"/> 4 <input type="checkbox"/>	1 <input type="checkbox"/> 2 <input type="checkbox"/> 3 <input type="checkbox"/> 4 <input type="checkbox"/>
1/2000	1/4000	1/10000	1/25000
1 <input type="checkbox"/> 2 <input type="checkbox"/> 3 <input type="checkbox"/> 4 <input type="checkbox"/>	1 <input type="checkbox"/> 2 <input type="checkbox"/> 3 <input type="checkbox"/> 4 <input type="checkbox"/>	1 <input type="checkbox"/> 2 <input type="checkbox"/> 3 <input type="checkbox"/> 4 <input type="checkbox"/>	1 <input type="checkbox"/> 2 <input type="checkbox"/> 3 <input type="checkbox"/> 4 <input type="checkbox"/>
1/50000	1/100000	1/100	
1 <input type="checkbox"/> 2 <input type="checkbox"/> 3 <input type="checkbox"/> 4 <input type="checkbox"/>	1 <input type="checkbox"/> 2 <input type="checkbox"/> 3 <input type="checkbox"/> 4 <input type="checkbox"/>	1 <input type="checkbox"/> 2 <input type="checkbox"/> 3 <input type="checkbox"/> 4 <input type="checkbox"/>	

(Unit: seconds)

Restart/Reset

To Set Restart/Reset Mode

This mode allows you to capture the information on single screens at any time by externally inputting restart/reset signals (HD/VD). To enter this mode, set the trigger shutter switches (6 to 8) on the rear panel of the camera as shown in the figure below.

To use restart/reset mode and high-rate scan mode simultaneously, set the high-rate scan mode switch (5) to ON (right side).

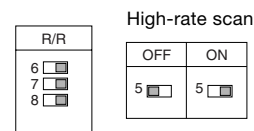

Long Exposure

The Restart/Reset function extends the CCD accumulation time, resulting in highly sensitive image capture. This function is effective when you cannot gain satisfactory sensitivity under normal operating conditions, or when you want to observe the trail of a moving object. Extend the VD interval (T) between external VD pulses.

